



OPERATORS HANDBOOK

WICKMAN

1.3/4" (44MM) / 1.3/4"-8S & 50MM-8

8 SPINDLE BAR AUTOMATIC LATHES



MORI-SAY

TANGI-FLOW PRODUCTS LTD

CUCCHI - BLT
BAR LOADING TECHNOLOGY
America Inc.

MANURHINKMX

www.wickman-usa.com



Tajmac-USA | Wickman
4950 W 79th St.
Indianapolis, IN 46268
Tel: 847 458 6400

We at Wickman Machine Tool are always working on improving our customer service. We want you, our customer, to feel confident that we are doing everything that we can to give you the best service possible.

Firstly, in order to improve our service; we need to improve the communication system between us and our customers. We have listed below a number of important contacts for you to reach the people you need to speak to directly with ease.

Reyna Rios – Spares/Sales

Office: 847 458 6400 Ext 4308
E-mail: rrios@tajmac-usa.com

Kelsey Like – Accounts

Office: 847 458 6400 Ext 4032
E-mail: klike@tajmac-usa.com

Bruce Renwick – Service & Technical Manager

Office: 847 458 6400 Ext 4033
E-mail: engineering@tajmac-usa.com

Customer service is our priority. We want to build strong relationships with all of you. Therefore, if you ever want to call up to negotiate availability, quality, price, turnaround times, responsiveness to your inquiries or any other factor that will affect your decision to buy from us, please feel free to do so and we will do whatever it takes to try and meet your requirements.

Kind regards

The Wickman Team

IMPORTANT:

The designs of all items described in this publication are the property of Wickman Bennett Machine Tool Company Limited and are subject to copyright.

Our designs are continuously being developed and we reserve the right to incorporate modifications when necessary and without notice.

Whilst every effort has been made to ensure the accuracy of information herein, Wickman Bennett Machine Tool company Limited do not accept liability for omissions and errors.

In all communications with us, please always quote the NUMBER of the machine as well as the size.

OPERATORS HANDBOOK

FOR

WICKMAN 1.3/4"-8, 1.3/4"-8S & 50mm-8

SPINDLE BAR AUTOMATIC LATHES

All Enquiries to:

Wickman Bennett Machine Tool Company Limited,
Banner Lane,
The Hill,
COVENTRY CV4 9GE

Telephone : 0203 465231
Telex : 311941

Frame 5, 8-Spindle
Bar, Operators

OPFR5/8B
29/09/88

TABLE OF CONTENTS

<u>DESCRIPTION</u>	<u>PAGE</u>
TABLE OF CONTENTS	1
PREFACE	2
HEALTH AND SAFETY	2-3
MACHINE SIZE / MODEL RANGE	4
MACHINE SERIAL / INSPECTION NUMBER	4
DETAILED CONTENTS LIST - Refer below for Summary List	5-6
SUMMARY CONTENTS LISTING	
Section One: Specifications	7-20
Section Two: Installation & Preliminary Checks	21-34
Section Three: Operator's Controls	35-40
Section Four: Summary of Operating Procedures	41-58
Section Five: Attachments	51-108

Wickman Bennett Machine Tool Co. Ltd., operate a policy of continual improvement. We therefore reserve the right to change the specifications and illustrations without notice.

PREFACE

This handbook provides the basic information and instructions necessary for the operation, and tooling of the Wickman 1.3/4"-8, 1.3/4"-8S (arranged for spindle stopping) and the 50mm-8 Spindle Bar Automatic Lathes with relay logic control.

The contents will familiarize the reader with the machine and control specifications, installation procedure, the functions of the Operator's controls, operating procedures, programming conventions, safety at work and all the relevant aspects of the machine.

The manual should be read thoroughly. It will enable the Operator to gain the knowledge required for the correct and efficient operation of the machine.

A Maintenance Manual and Parts List is also available for the 1.3/4"-8 1.3/4"-8S and 50mm-8 machines.

HEALTH AND SAFETY

Health and Safety at Work Act, 1974 - U.K. users only.

In accordance with the requirements of the Health and Safety at Work Act 1974, this manual embodies the necessary information to ensure that the machine tool can be operated properly and with safety. It should be clearly understood that the operator must be properly trained, have the required skills and be authorised to operate the machine.

If it should arise that the person authorised to operate the machine is undergoing training, he must be under the close supervision of another skilled and authorised person.

Adequate information is provided in this handbook, together with the Maintenance Manual, to enable the machine to be serviced and maintained in a satisfactory condition by engineers and electricians who have the necessary skills and authority. It is recommended that a 'Permit to Work' system, as detailed in BS5304;1988 "Safety of Machinery", should be operated.

HEALTH AND SAFETY (Continued)

It is important that the various statutory regulations which are applicable, eg, 'The Protection of Eyes Regulations' are complied with.

Operating Discipline

- (I) A clean, neat and well ordered machine and working area is the first essential of safety at work.
- (II) All guards, cover plates, cabinet doors and the tooling area guards must be in place or closed before any production run commences.
- (III) Never leave articles lying on any working surface where there is a danger that they may be dislodged by: any moving part of the machine, vibration, etc.
- (IV) Never wear rings, watches, neck-ties or loose-sleeved clothing when working on the machine.
- (V) Never operate the machine in excess of its rated capacity.
- (VI) Know where the EMERGENCY STOP BUTTON is.
- (VII) Never reach across a moving or rotating part of the machine.
- (VIII) Never enter the tooling area or any other working part of the machine when the machine is running on production.
- (IX) When tool setting, changing tools or making adjustments, never enter the tooling area until the machine has been shut down.
- (X) When carrying out maintenance work, never enter any part of the machine, either mechanical or electrical, until the machine has been shut down and the isolator on the electrical control panel is in its "off" position, disconnecting the power supply.
- (XI) When working with lubrication oils and cutting oils of the soluble and straight cutting oil types, cleanliness is essential. Precautions must be taken to avoid all unnecessary contact with oil by ensuring that the machine's protective devices against coolant and oil spray are correctly closed and that protective clothing is worn. Never wear oil soaked clothes or place oily rags or tooling in the pockets of wearing apparel. Always wash oil from the body as soon as possible after contamination.

The Safe Operation Of Work Holding Devices

Collet equipment and collet operating mechanisms must always be kept in first class condition, in order to ensure that the bar is securely gripped to withstand all the applied cutting forces. Tooling area guards must always be closed when the machine is in the "run" condition.

It is important that the various statutory regulations which are applicable, eg, 'The Protection of Eyes Regulations' are complied with.

MACHINE SIZE / MODEL RANGE

- WICKMAN 2.5/8"-6 SPINDLE BAR AUTOMATIC LATHE
- WICKMAN 3.1/4"-6 SPINDLE BAR AUTOMATIC LATHE
- WICKMAN 1.3/4"-8 SPINDLE BAR AUTOMATIC LATHE *
- WICKMAN 1.3/4"-8S SPINDLE STOPPING MACHINE *
- WICKMAN 50mm-8 SPINDLE BAR AUTOMATIC LATHE *
- WICKMAN 7.1/4"-6 SPINDLE HYDRAULIC CHUCKING AUTOMATIC LATHE
- WICKMAN 6"-8 SPINDLE HYDRAULIC CHUCKING AUTOMATIC LATHE

This Handbook applies only to the Machines marked *, above.

MACHINE SERIAL / INSPECTION NUMBER

In the event that queries arise with regard to the Operation of the machine, it is important to note the following details which would need to be given to Wickman Bennett in all correspondence, ie:

Machine Inspection/Serial number, Machine size and Model.

The machine Inspection/Serial Number must always be quoted and is stamped on the machined-rim of the Tray of the machine, on the left hand side, close to the Operators position. Additionally the number is also engraved on the machine Manufacturing Plate (WSP500) which is affixed to the Main Drive Housing casting at the rear of the machine.

Reference to this number will facilitate any service that may be required.

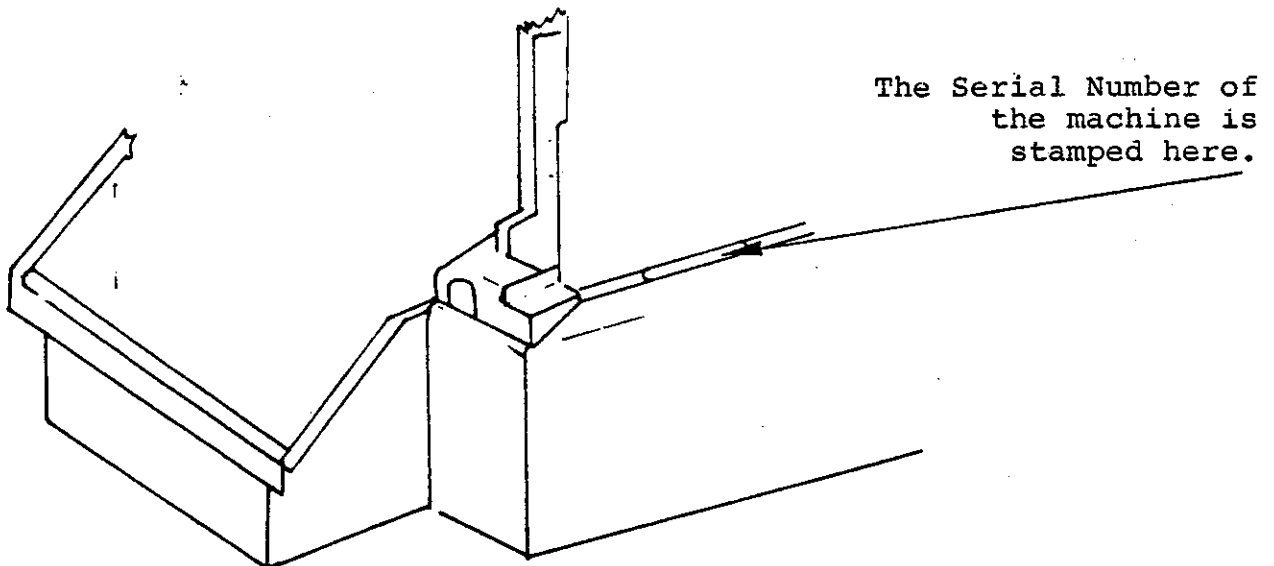

DETAILED CONTENTS LIST

PAGE

SECTION ONE - SPECIFICATIONS

7

- 1.1 Machine Specifications
- 1.2 Electrical Specifications
- 1.3 Capacity Charts

SECTION TWO - INSTALLATION AND PRELIMINARY CHECKS

21

- 2.1 Installation and Lifting
- 2.2 Machine Foundation
- 2.3 Levelling the Machine and Sundry Requirements
- 2.4 Electrical Equipment
- 2.5 Lubrication
- 2.6 Procedures before Starting the Machine

SECTION THREE - OPERATORS CONTROLS

35

- 3.1 Controls
- 3.2 Electrical Controls
- 3.3 Manual Controls

SECTION FOUR - OPERATING ADJUSTMENTS AND PROCEDURES

41

- 4.1 Changing Spindle Speed Gears
- 4.2 Changing Feed Gears
- 4.3 Changing Feed Fingers and Steady Bushes
- 4.4 Changing Collets
- 4.5 Setting Bar Feed Stroke
- 4.6 Bar Feed Cams
- 4.7 Adjusting the Bar Stop
- 4.8 Bar Loading
- 4.9 Setting the Longitudinal Slides
- 4.10 Cross Slide Adjustment
- 4.11 Cross Slide Stoke Adjustment
- 4.13 Other Adjustments

SECTION FIVE - ATTACHMENTS

- 5.1 High Speed Drilling
- 5.2 Auxiliary Longitudinal Motion
- 5.3 Jackshafts
- 5.4 Slow Speed Reaming
- 5.5 Independent Reaming
- 5.6 Threading Attachments
- 5.7 Fitting Drive Units, Jackshafts and Threading Units
- 5.8 Setting Threading Attachments
- 5.9 Threading Attachments
- 5.10 Chasing Attachments
- 5.11 Threading Attachment Return Check Switch
- 5.12 Auxiliary Cross Slide Operation
- 5.13 Synchronous Drive
- 5.14 Section Charts

SECTION ONE - SPECIFICATIONS

The following charts of machine specifications apply to various models within the range. It is therefore essential that the user correctly identifies the specification list that is applicable.

1.1 Machine Specifications 1.3/4"-8 Spindle Bar Automatic

Description	Unit	Specification	Remarks
<u>CAPACITY</u>			
Bar capacity:			
Round	mm	44.4	Solid Collet
Hexagon A/flats	mm	38.0	Solid Collet
Square A/flats	mm	31.0	Solid Collet
Round	mm	44.4	Master Collet/Pads
Hexagon A/flats	mm	38.0	Master Collet/Pads
Square A/flats	mm	31.0	Master Collet/Pads
Bar feed stroke:			
Station 1	mm	12 to 127	Standard Cams
Station 1	mm	127 to 254	Optional Extra Cams
Approach strokes:			
Centre block and	mm	127	Standard Cams
Independant Slide	mm	89	Optional Extra Cams
Feed strokes:			
Centre block	mm	0 to 127	
Independent slides	mm	0 to 143	
Cross slides:			
Stn.1	mm	0 to 44	
Stn.2	mm	0 to 46	
Intermediate Stns. 3 & 4	mm	4.76 to 28.6	
Stn.5	mm	0 to 63	Using hole 'A'
Stn.6	mm	0 to 32	Using hole 'B'
Stn.6	mm	0 to 63	Using hole 'A'
Stn.6	mm	0 to 32	Using hole 'B'
Intermediate Stns. 7 & 8	mm	4.76 to 31.8	
Spindle speed range:	r/min	96 to 1243	
Number of steps:		24	
Feed range @ 127mm stroke	mm/rev	0.09 to 1.50	
Cycle time range:		7.1 to 922	
Idle time		3	
<u>GENERAL</u>			
Required Floor Space:	mm	1562 x 4200	O/all length excludes the stock carriage.
	mm	1562 x 6626	O/all length excludes the stock carriage.
Shipping Weight (Net)	Kg	12,700	Excluding Stk. Carrg.

1.1 Machine Specifications 1.3/4"-8S Spindle Stopping Machine

Description	Unit	Specification	Remarks
<u>CAPACITY</u>			
Bar capacity:			
Round	mm	44.4	Solid Collet
Hexagon A/flats	mm	38.0	Solid Collet
Square A/flats	mm	31.0	Solid Collet
Round	mm	44.4	Master Collet/Pads
Hexagon A/flats	mm	38.0	Master Collet/Pads
Square A/flats	mm	31.0	Master Collet/Pads
Bar feed stroke:			
Station 1	mm	12 to 127	Standard Cams
Station 1	mm	32 to 159	Optional Extra Cams
Approach strokes:			
Centre block and	mm	127	Standard Cams
Indepenant Slides	mm	89	Optional Extra Cams
Feed strokes:			
Centre block	mm	0 to 127	
Independent slides	mm	0 to 143	
Cross slides:			
Stn.1	mm	0 to 44	
Stn.2	mm	0 to 46	
Intermediate Stns. 3 & 4	mm	4.76 to 28.6	
Stn.5	mm	0 to 63	Using hole 'A'
Stn.5	mm	0 to 32	Using hole 'B'
Stn.6	mm	0 to 63	Using hole 'A'
Stn.6	mm	0 to 32	Using hole 'B'
Intermediate Stns. 7 & 8	mm	4.76 to 31.8	
Spindle speed range:	r/min	117 to 1044	
Number of steps:		19	
Feed range @ 127mm stroke	mm/rev	0.07 to 1.25	
Cycle time range:		9.0 to 922	
Idle time		3	
<u>GENERAL</u>			
Required Floor Space:	mm	1562 x 4200	O/all length excludes the stock carriage.
	mm	1562 x 6626	O/all length excludes the stock carriage.
Shipping Weight (Net)	Kg	12,700	Excluding Stk. Carrg.

1.1 Machine Specifications 50mm-8 Spindle Bar Automatic

Description	Unit	Specification	Remarks
<u>CAPACITY</u>			
Bar capacity:			
Round	mm	50.0	Solid Collet
Hexagon A/flats	mm	43.3	Solid Collet
Square A/flats	mm	35.35	Solid Collet
Round	mm	50.0	Master Collet/Pads
Hexagon A/flats	mm	43.3	Master Collet/Pads
Square A/flats	mm	35.35	Master Collet/Pads
Bar feed stroke:			
Standard Cams	mm	12 to 127	In Station 1
Special Cams	mm	127 to 254	Optional extra
Approach strokes:			
Centre block and	mm	127	Standard Cams
Independent Slides	mm	89	Optional Extra Cams
Cross slides:			
Stn.1	mm	0 to 44	
Stn.2	mm	0 to 46	
Intermediate Stns. 3 & 4	mm	4.76 to 28.6	
Stn.5	mm	0 to 63	Using hole 'A'
	mm	0 to 32	Using hole 'B'
Stn.6	mm	0 to 63	Using hole 'A'
	mm	0 to 32	Using hole 'B'
Intermediate Stns. 7 & 8	mm	4.76 to 31.8	
Spindle speed range:	r/min	131 to 1044	
Number of steps:		19	
Feed range @ 127mm stroke	mm/rev	0.09 to 1.25	
Cycle time range:		9.0 to 818	
Idle time		3	
<u>GENERAL</u>			
Required Floor Space:	mm	1562 x 4200	O/all length excludes the stock carriage.
	mm	1562 x 6626	O/all length excludes the stock carriage.
Shipping Weight (Net)	Kg	12,700	Excludes Stk. Carrg.

1.1 Machine Specifications

Description	Unit	Specification	Remarks
GENERAL			
Coolant Tank Capacity	Litres	820	
Jacking Screws	4 off		
Service Tool Kit	1 off		Toolbox, spanners, wrenches, tool height setting gauge
LUBRICATION			
Main Spindle Bearings			See Section on Lubrication
Main Drive Housing			Splash lubrication
All Electric Motors			Sealed for life - maintenance free

1.2 Electrical Specifications

Description	Unit	Specification	Remarks
MAINS SUPPLY CONDITIONS:			
Line Voltage	Volts	220 to 575	Customer to advise.
Allowable variation in V	%	+/-10	About nominal
Frequency	Hz	50 or 60	Customer to advise.
Allowable variation in Hz	%	+/-1	About nominal
Total power requirements	kW	Variable	Dependent upon Customer's Mains Supply
MAIN SPINDLE MOTOR:			
Foot mounted, totally enclosed, fan cooled	kW	22	Standard
	kW	30	Optional
	r/min	1450	At 50Hz
	r/min	1450	At 60Hz
SWARF CONVEYOR MOTOR:			
Flange Mounted, totally enclosed fan cooled motor	kW	0.18	Applicable to Wickman Bennett standard screw type swarf conveyor.

Power to the equipment is supplied through the Electrical Control Enclosure.

1.3 Capacity Charts

<u>Drawing No:</u>	<u>Description:</u>	<u>Page</u>
500Z24A	Capacity Chart 1.3/4"-8, S and 50mm End View	14
500Z25B	Capacity Chart 1.3/4"-8, S and 50mm Front View	16
572Y115A	Speed & Feed Chart 1.3/4"-8 Bar Auto	17
512Y259	Speed & Feed Chart 1.3/4"-8S Spindle Stopper	18
510Y180	Speed & Feed Chart 50mm-8 Bar Auto	19

STATION	CROSS SLIDE STROKES											
	1		2		3 & 4		5		6		7 & 8	
	LEVER						POSITION					
	A		B		A		B		A		B	
INS.	MM.	INS.	MM.	INS.	MM.	INS.	MM.	INS.	MM.	INS.	MM.	
APPROACH STROKE AT MIN FEED	1 1/8	41.3	2 3/8	55.6	1 5/8	33.3	2	50.8	1	25.4	1 3/8	44.5
APPROACH STROKE AT MAX FEED	2	50.8	2	50.8	2 5/4	31.8	2 1/8	15.9	1 3/8	34.9	1 1/8	28.6
FEED STROKE	0 TO 1 1/4	0 TO 49.4	0 TO 1 3/8	0 TO 38.1	0 TO 1 1/8	0 TO 29.2	0 TO 1 1/4	0 TO 31.8	0 TO 1 1/2	0 TO 38.1	0 TO 1 1/4	0 TO 31.8
ADJUSTMENT FORWARD	3/8	9.5	3/8	9.5	3/8	9.5	3/8	9.5	3/8	9.5	3/8	9.5
ADJUSTMENT BACKWARDS	1/8	20.6	1/8	20.6	7/8	22.2	1/8	20.6	1/8	20.6	1/8	20.6

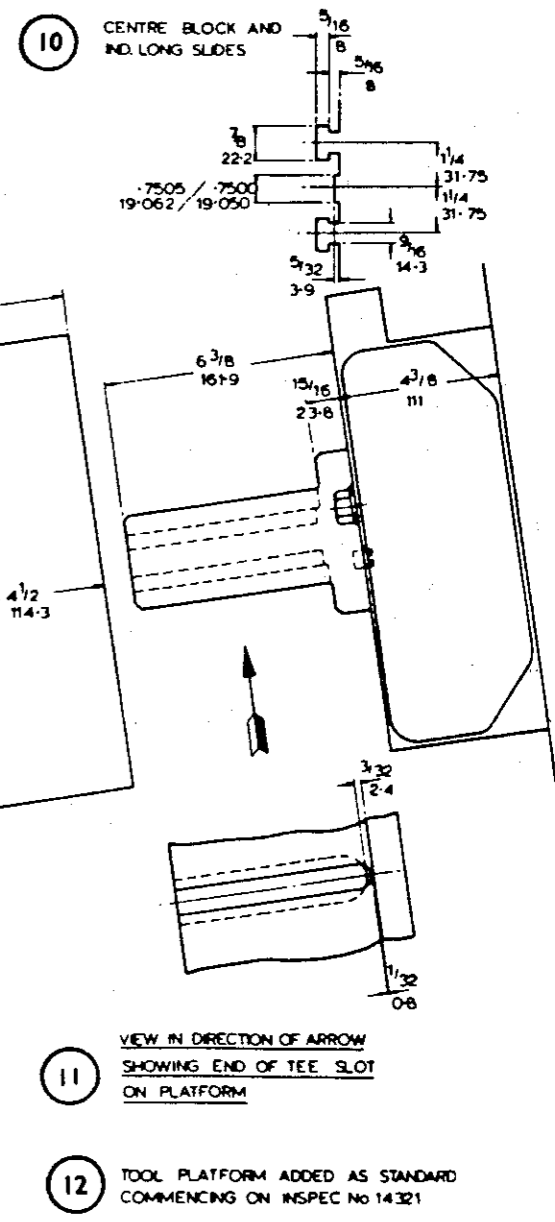
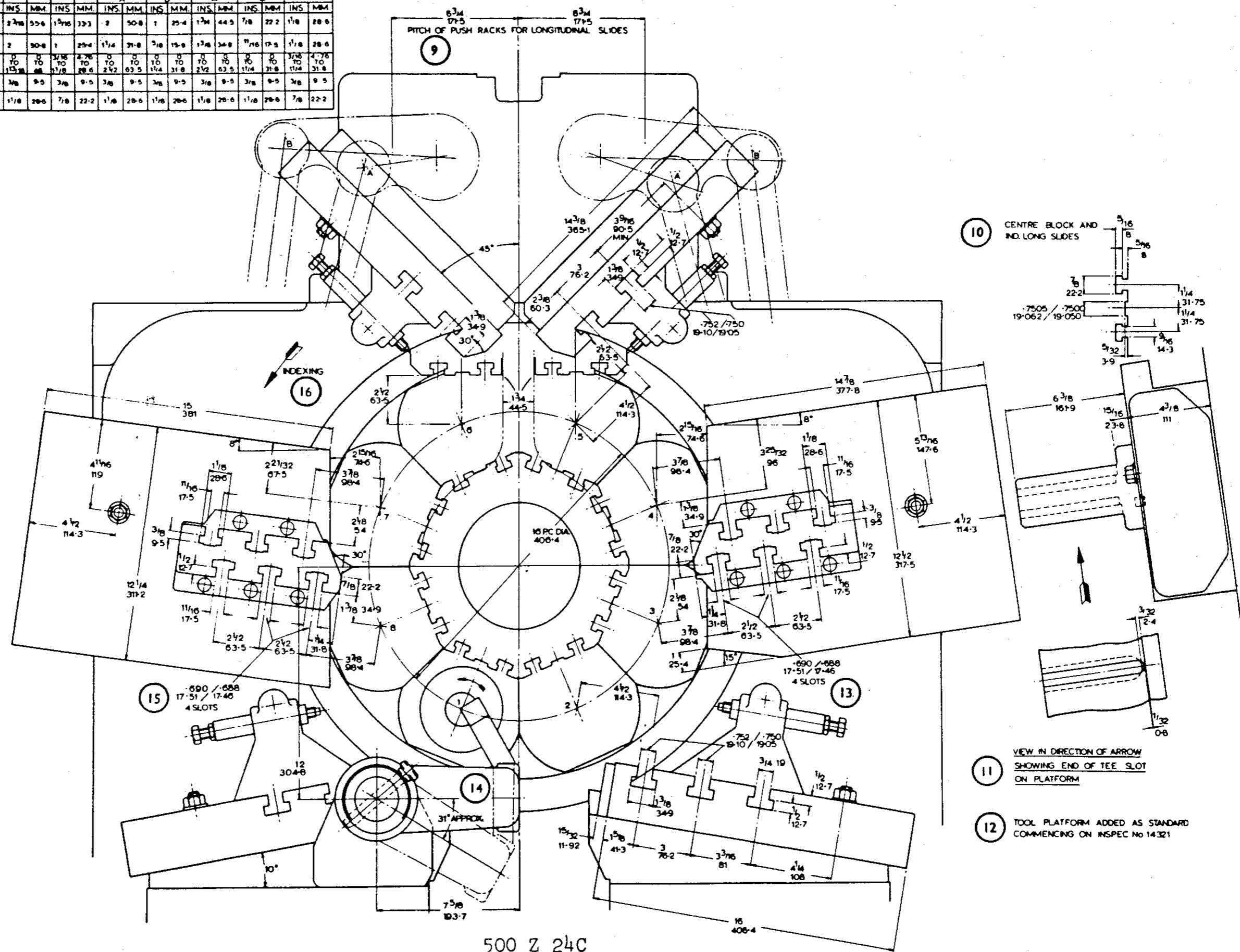

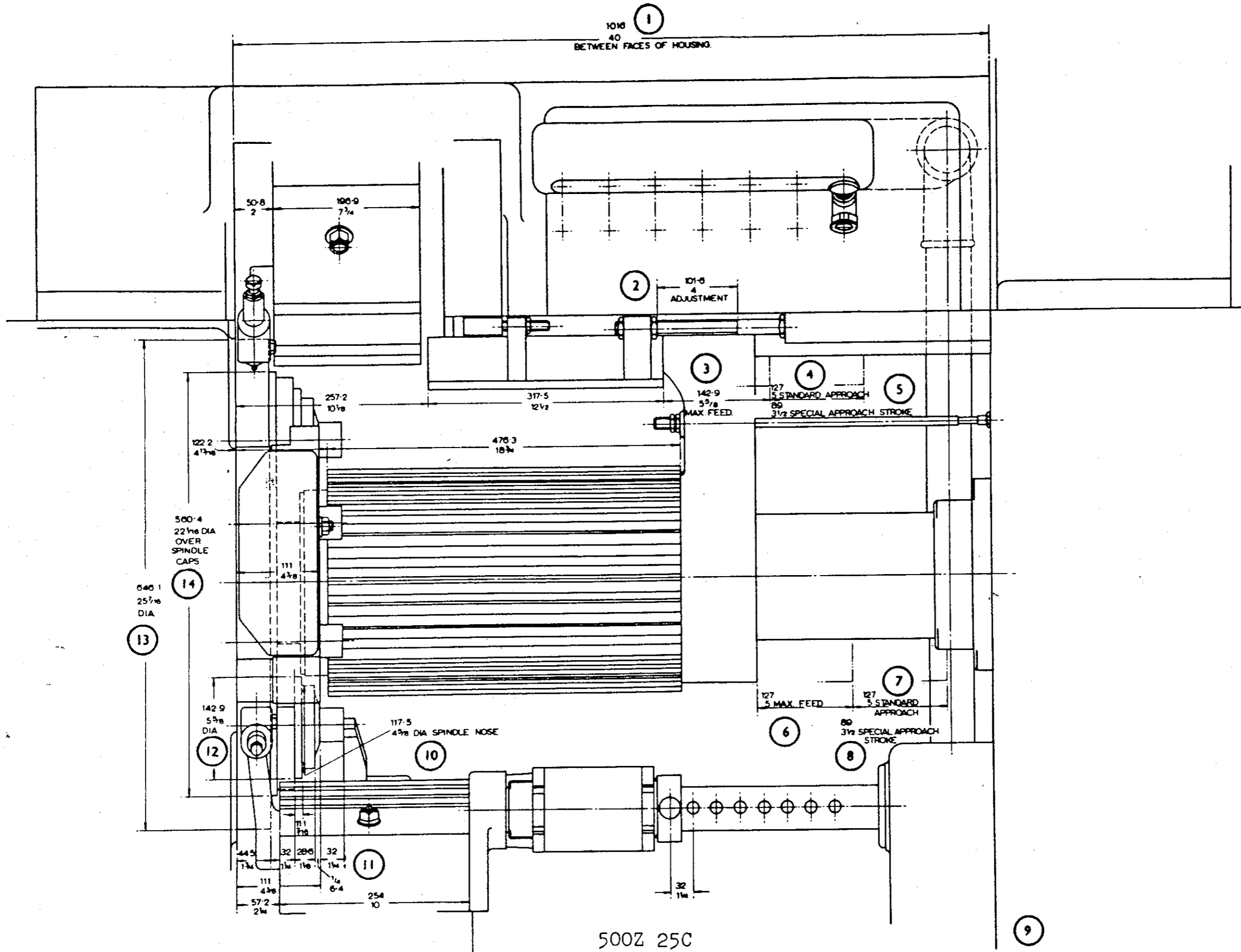

Wickman 1 3/4"-8

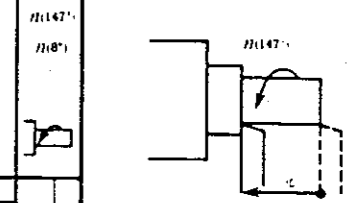
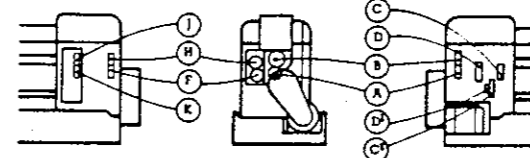

N MIN	CC'																DD'																L	DWS			
	50	47	45	42	40	37	35	32	30	27	25	22	20	18	16	14	50	47	45	42	40	37	35	32	30	27	25	22	20	18	16	1			2	3	4
1243	1061	985	858	782	681	619	536	484	414	359	312	273	240	211	188	1243	1061	985	858	782	681	619	536	484	414	359	312	273	240	211	188	1	2	3	4	5	125
44	27	47	24	71	78	82	9	9	9	10	11	12	13	14	15	44	27	47	24	71	78	82	9	9	9	10	11	12	13	14	15	1	2	3	4	5	125

572 Y 115A

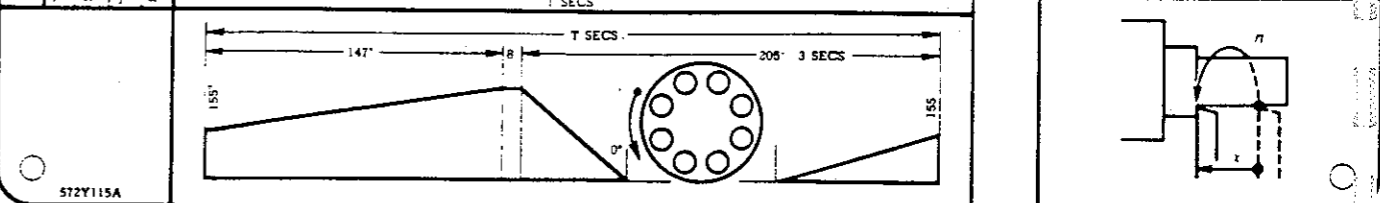

Wickman 1 3/4"-8S

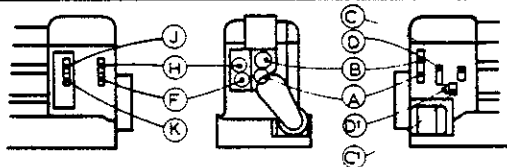

n (147°)

n (8°)

n (147°)

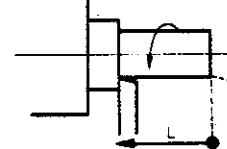

CC' DP'

A 42 40 37 35 32 30 27 50 47 45 42 40 37 35 32 30 27 24 22

B 45 47 50 52 55 57 60 37 40 42 45 47 50 52 55 57 60 63 65

N/MIN 1044 951 828 753 652 589 504 468 409 371 324 294 257 234 202 181 157 131 117

n (147°) n (8°)

L

25 5 75 10 20 30 40 50 125 M/M

-25 -50 -75 1 2 3 4 5 INS

44	27	47	24	9	95	106	113	126	137	155	164	184	199	22	24	26	30	34	3	43	51	57	100	5.4	25	5	75	10	20	30	40	50	125	
42	29	47	24	98	104	115	124	139	15	169	181	20	22	25	27	31	33	38	42	48	57	63	111	5	22	45	67	9	18	27	36	45	113	
39	32	47	24	11	11.8	13.1	14.1	15.9	17.2	19.6	21	23	26	29	31	36	39	45	49	57	67	75	133	7.2	9	37	55	75	115	22	30	37	94	
42	29	44	27	11	11.9	13.3	14.3	16.1	17.4	19.9	21	23	26	29	32	36	39	45	49	57	68	76	135	7.3	9	37	56	74	115	22	30	37	93	
37	34	47	24	12	12.9	14.4	15.5	17.4	19	22	23	26	28	32	35	40	43	50	54	63	75	83	148	8	17	34	51	69	114	20	27	34	85	
39	32	44	27	12.7	13.6	15.2	16.4	18.5	20	23	25	28	30	34	37	42	46	53	58	67	81	89	159	8.6	15	31	47	63	113	19	25	31	79	
34	37	47	24	13.7	14.7	16.4	17.8	20	21	25	27	30	33	37	41	46	51	58	64	74	89	98	176	9.6	14	28	43	57	111	17	23	28	71	
37	34	44	27	13.8	14.9	16.6	18	20	22	25	27	31	33	38	41	47	51	59	65	75	90	100	179	9.7	14	28	42	56	111	17	22	28	70	
39	32	42	29	13.9	14.9	16.7	18.1	20	22	25	29	31	34	38	42	47	52	59	65	76	90	100	179	9.7	14	28	42	56	111	17	22	28	70	
32	33	47	24	15	16.1	18.1	19.6	22	24	28	30	34	37	42	45	52	57	65	71	83	99	110	198	11	13	26	38	51	10	15	20	26	64	
37	34	42	28	15.2	16.3	17.9	19.9	23	25	28	30	34	37	42	46	53	57	66	72	84	101	112	202	11	12	25	37	49	10	15	20	25	61	
34	37	44	27	15.8	17	19.1	21	24	26	29	32	36	39	44	48	55	60	70	76	88	106	118	213	12	12	24	35	47	94	14	19	24	59	
29	42	47	24	17.2	18.6	21	23	26	28	32	35	39	43	49	53	61	67	77	84	98	117	130	235	11	11	22	32	43	86	13	17	22	54	
32	39	44	27	17.4	18.8	21	23	26	28	33	35	40	43	49	54	61	67	77	85	99	118	131	238	13	11	21	31	42	84	13	17	21	53	
34	37	42	29	17.4	18.8	21	23	26	29	33	35	40	44	50	54	62	68	78	86	99	119	132	239	13	11	21	31	42	84	13	17	21	53	
37	34	39	32	17.5	18.9	21	23	26	29	33	35	40	44	50	54	62	68	78	85	100	119	133	243	13	11	21	31	42	84	13	17	21	53	
27	44	47	24	19	21	23	25	29	31	36	39	44	48	55	59	68	75	86	94	110	131	146	264	14	10	19	29	38	76	11	15	19	48	
32	39	42	29	19.2	21	23	25	29	32	38	39	44	48	55	60	69	75	86	95	111	133	147	265	14	10	19	29	38	75	11	15	19	48	
29	42	44	27	20	22	25	27	30	33	38	41	47	51	58	63	72	78	92	100	117	140	155	281	15	9	18	27	36	72	11	14	18	45	
34	37	39	32	20	22	25	27	31	33	39	41	47	51	58	64	73	80	92	101	118	141	156	283	15	9	18	26	35	70	10	14	18	44	
32	39	37	34	24	27	30	33	37	41	47	51	58	63	72	79	89	99	115	125	146	175	195	355	19	7	14	21	28	56	84	11	14	35	
27	44	42	29	25	27	30	33	38	41	48	51	58	64	73	80	91	100	115	126	148	177	196	357	19	7	14	20	27	54	81	11	14	34	
29	42	39	32	26	28	32	35	40	43	50	54	61	66	77	84	93	105	121	132	155	186	207	377	20	6	12	18	24	48	66	91	12	16	30
24	47	44	27	26	28	32	35	40	44	51	54	63	68	78	85	97	106	122	134	157	188	209	381	21	6	12	18	24	48	66	91	12	16	30
32	39	34	28	31	35	38	44	48	55	60	68	74	85	93	106	116	135	148	173	207	231	422	23	6	12	18	24	48	66	91	12	16	30	
29	42	37	34	29	31	35	38	44	48	56	60	68	75	86	93	107	117	135	148	174	209	232	424	23	6	12	18	24	48	66	91	12	16	30
27	44	37	34	29	31	35	38	44	48	56	60	68	75	86	94	107	118	136	149	175	209	232	424	23	6	12	18	24	48	66	91	12	16	30
24	47	42	29	29	32	36	39	45	49	57	61	69	76	87	95	109	119	137	151	177	212	235	429	23	5	11	17	23	46	69	92	11	29	
19	52	47	24	30	32	37	40	46	50	58	63	72	78	90	98	112	123	142	155	182	218	243	444	24	5	11	17	23	46	69	92	11	29	
27	44	37	34	32	34	39	43	49	54	62	67	76	83	96	104	118	131	152	166	194	234	260	475	26	5	10	16	21	42	63	84	10	26	
29	42	34	37	33	36	41	43	52	57	65	70	80	88	100	110	124	138	160	175	205	245	273	499	27	5	10	15	2	4	6	8	10	25	
24	47	39	32	34	37	42	46	53	58	67	72	82	90	103	112	128	141	163	179	209	250	279	510	28	5	10	15	2	4	6	8	10	25	
19	52	44	27	35	38	42	48	55	60	69	75	85	93	107	117	132	147	170	195	218	262	291	533	29	4	9	14	19	38	57	76	95	24	
29	42	32	39	37	40	46	50	57	63	73	79	89	98	113	123	139	154	179	196	229	275	306	560	30	4	9	14	18	36	54	72	9	23	
27	44	34	37	37	40	46	50	58	63	74	79	90	99	113	123	141	155	179	197	230	276	307	562	30	4	9	14	18	36	54	72	9	23	
24	47	37	34	38	41	47	51	58	64	74	80	91	100	114	125	142	157	182	199	234	280	312	571	31	4	9	14	18	36	54	72	9	23	
19	52	42	29	39	43	49	53	61	67	78	84	95	104	120	131	148	165	190	209	245	294	327	599	33	4	9	14	18	36	54	72	9	23	
27	44	32	39	41	45	51	56	64	70	81	88	100	110	126	137	156	173	200	220	257	309	344	631	34	4	9	14	18	36	54	72	9	23	
24	47	34	37	44	48	54	60	69	75	87	94	107	117	135	147	167	185	215	235	276	331	369	677	37	3	8	12	15	30	45	60	75	19	
19	52	39	32	46	50	51	63	72	79	92	99	113	124	142	155	176	195	226	248	290	349	388	712	39	3	8	12	15	30	45	60	75	19	
27	44	29	42	48	53	60	66	76	83	96	104	118	130	150	163	185	205	238	260	305	364	409	751	41	3	7	11	14	28	42	56	7	18	
24	47	32	39	49	53	61	66	77	84	97	105	120	131	151	165	187	208	240	263	309	366	413	758	41	3	7	11	14	28	42	56	7	18	
19	52	37	34	51	56	64	70	80	88	102	110	126	138	158	173	197	218	254	277	325	385	434	797	43	3	7	11	14	28	42	56	7	18	
24	47	29	42	57	63	72	79	90	100	115	124	142	155	179	195	222	246	285	316	365	434	490	901	49	2	7	11	14	28	42	56	7	18	
19	52	34	37	60	66	75	82	95	104	121	130	149	163	187	205	232	258	300	331	385	456	515	947	52	2	7	11	14	28	42	56	7		

WICKMAN 50-8

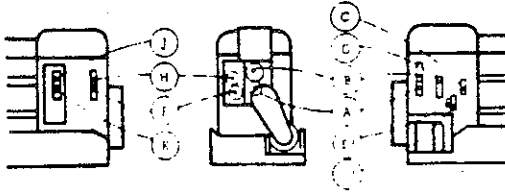

r(147°)

r(8°)

r(147°)

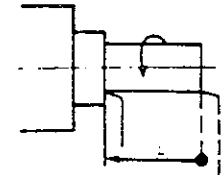

		CC'								DD'								L																
A	B	45	42	40	37	35	32	30	27	50	47	45	42	40	37	35	32	30	27	24	r(147°)													
		r(8°)																r(147°)																
																		mm																
																		in																
r/min		1200	1084	951	828	753	652	589	504	468	409	371	324	294	257	234	202	181	157	131	L													
																		mm																
																		in																
44	27	47	24	8-2	9	9-6	10-6	11-3	12-6	13-7	15-5	16-4	18-4	19-9	22	24	26	30	34	37	43	51	100	5-4	2-5	5	7-5	10	20	30	40	50	125	
42	28	47	24	8-9	9-8	10-4	11-5	12-4	13-9	15	16-3	18-1	20	22	25	27	31	33	38	42	48	57	111	6	2-2	4-5	6-7	9	10	17	27	36	45	113
40	32	47	24	10	11	11-8	13-1	14-1	15-9	17-2	19-6	21	23	26	29	31	36	39	45	49	57	67	133	7-2	1-9	3-7	5-6	7-4	15	22	30	37	94	
38	37	47	24	10-1	11-1	11-9	13-3	14-3	16-1	17-4	19-9	21	23	26	29	32	36	39	45	49	57	68	135	7-3	1-9	3-7	5-6	7-4	15	22	30	37	93	
36	34	47	24	10-8	12	12-9	14-4	15-5	17-4	19	22	23	26	28	32	35	40	43	50	54	63	75	148	8	1-7	3-4	5-1	6-8	14	20	27	34	85	
34	32	44	27	11-4	12-7	13-8	15-2	16-4	18-5	20	23	25	28	30	34	37	42	46	53	58	67	81	159	8-6	1-6	3-1	4-7	6-3	13	19	25	31	79	
32	37	47	24	12-3	13-7	14-7	16-4	17-8	20	21	25	27	30	33	37	41	46	51	58	64	74	89	176	9-6	1-4	2-8	4-3	5-7	11	17	23	28	71	
30	34	44	27	12-4	13-8	14-9	16-8	18	20	22	25	27	31	33	38	41	47	51	58	65	75	90	179	9-7	1-4	2-8	4-2	5-6	11	17	22	28	70	
28	32	42	29	12-5	13-9	14-9	16-7	18-1	20	22	25	29	31	34	38	42	47	52	59	65	76	90	179	9-7	1-4	2-8	4-2	5-6	11	17	22	28	70	
26	33	47	24	13-4	15	16-1	18-1	19-6	22	24	28	30	34	37	42	45	52	57	65	71	83	99	198	11	1-3	2-6	3-8	5-1	10	15	20	26	64	
24	34	42	28	13-6	15-2	16-3	17-9	19-9	23	25	28	30	34	37	42	46	53	57	66	72	84	101	202	11	1-2	2-5	3-7	4-9	10	15	20	25	61	
22	37	44	27	14-1	15-8	17	19-1	21	24	26	29	32	36	39	44	48	55	60	70	76	88	106	213	12	1-2	2-4	3-5	4-7	9-4	14	19	24	59	
20	42	47	24	15-3	17-2	18-6	21	23	26	28	32	35	39	43	49	53	61	67	77	84	98	117	235	13	1-1	2-2	3-2	4-3	8-6	13	17	22	54	
18	39	44	27	15-4	17-4	18-8	21	23	26	28	33	35	40	43	49	54	61	67	77	85	99	118	238	13	1-1	2-1	3-1	4-2	8-4	13	17	21	53	
16	37	42	29	15-5	17-4	18-8	21	23	26	29	33	35	40	44	50	54	62	68	78	86	99	119	239	13	1-1	2-1	3-1	4-2	8-4	13	17	21	53	
14	31	34	39	15-6	17-5	18-9	21	23	26	29	33	35	40	44	50	54	62	68	78	85	100	119	240	13	1-1	2-1	3-1	4-2	8-4	13	17	21	53	
12	27	44	47	16-9	19	21	23	25	29	31	36	39	44	48	55	59	68	75	86	94	110	131	264	14	1-0	1-9	2-9	3-8	7-6	11	15	19	48	
10	29	42	29	17	19-2	21	23	25	29	32	38	39	44	48	55	60	69	75	86	95	111	133	266	14	1-0	1-9	2-9	3-8	7-6	11	15	19	48	
8	32	44	27	17-8	20	22	25	27	30	33	38	41	47	51	58	63	72	78	92	100	117	140	281	15	-90	1-8	2-7	3-6	7-2	11	14	18	45	
6	34	37	39	17-9	20	22	25	27	31	33	39	41	47	51	58	64	73	80	92	101	118	141	283	15	-88	1-8	2-6	3-5	7-0	10	14	18	44	
4	32	38	37	21	24	27	30	30	37	41	47	51	58	63	72	79	89	99	115	125	145	175	355	19	-70	1-4	2-1	2-8	5-6	8-4	11	14	35	
2	27	44	42	21	25	27	30	33	38	41	48	51	58	64	73	80	91	100	115	126	148	177	357	19	-68	1-4	2-0	2-7	5-4	8-1	11	14	34	
1	24	42	39	23	26	28	32	35	40	43	50	54	61	66	77	84	93	105	121	132	155	186	377	20	-65	1-3	2-0	2-7	5-2	7-8	10	13	33	
0.8	24	47	44	27	24	28	32	35	40	44	51	54	63	68	78	85	97	106	122	134	157	188	381	21	-65	1-3	2-0	2-7	5-2	7-8	10	13	33	
0.6	22	38	34	27	25	28	31	35	40	44	51	54	62	67	76	83	93	103	117	130	151	182	422	23	-60	1-2	1-8	2-4	4-8	7-2	9-6	12	30	
0.4	29	42	37	34	25	29	31	35	40	44	51	54	62	67	76	83	93	103	117	130	151	182	424	23	-60	1-2	1-8	2-4	4-8	7-2	9-6	12	30	
0.2	27	44	38	32	26	29	31	35	40	44	51	54	62	67	76	83	93	103	117	130	151	182	424	23	-60	1-2	1-8	2-4	4-8	7-2	9-6	12	30	
0.1	24	47	42	28	26	29	32	36	40	44	51	54	62	67	76	83	93	103	117	130	151	182	429	23	-58	1-1	1-7	2-3	4-6	6-9	9-2	11	29	
0.08	19	52	47	24	27	30	32	37	40	46	50	58	63	72	78	90	98	112	123	142	156	182	218	444	24	-58	1-1	1-7	2-3	4-6	6-9	9-2	11	29
0.06	27	44	37	34	28	32	34	38	43	48	54	62	67	76	83	93	104	118	131	152	166	194	234	475	26	-52	1-0	1-6	2-1	4-2	6-3	8-4	10	26
0.04	29	42	34	37	29	33	36	41	43	52	57	65	70	80	86	100	110	124	138	160	175	205	245	499	27	-50	1-0	1-5	2	4	6	8	10	25
0.02	24	47	38	32	30	34	37	42	46	53	58	67	72	82	90	103	112	128	141	163	178	208	250	510	28	-50	1-0	1-5	2	4	6	8	10	25
0.01	19	52	44	27	31	35	38	42	48	55	60	69	75	85	93	107	117	132	147	170	186	218	262	533	29	-48	-95	1-4	1-9	3-8	5-7	7-6	9-5	24
0.008	29	42	32	39	32	37	40	46	50	57	63	73	79	89	98	113	123	139	154	179	196	229	275	560	30	-45	-90	1-4	1-8	3-6	5-4	7-2	9	23
0.006	27	44	34	37	33	37	40	46	50	58	63	74	79	90	99	113	123	141	156	179	197	230	276	562	30	-45	-90	1-4	1-8	3-6	5-4	7-2	9	23
0.004	24	47	37	34	34	38	41	47	51	58	64	74	80	91	100	114	125	142	157	182	199	234	280	571	31	-45	-90	1-4	1-8	3-6	5-4	7-2	9	23
0.002	19	52	42	29	35	39	43	49	53	61	67	78	84	95	104	120	131	148	165	190	209	245	294	599	33	-43	-85	1-3	1-7	3-4	5-1	6-8	8-5	21
0.001	27	44	32	39	36	41	45	51	56	64	70	81	88	100	110	126	137	156	173	200	220	257	309	631	34	-40	-80	1-2	1-6	3-2	4-8	6-4	8-0	20
0.0008	24	47	34	37	39	44	48	54	60	69	75	87	94	107	117	135	147	167	185	215	235	276	331	677	37	-38	-75	1-1	1-5	3-0	4-5	6-0	7-5	19
0.0006	19	52	39	32	41	46	50	51	63	72	79	92	99	113	124	142	155	176	195	226	248	290	349	712	39	-35	-70	1-0	1-4	2-8	4-2	5-6	7	18
0.0004	27	44	29	42	42	48	53	60	66	76	83	96	104	118	130	150	163	185	205	238	260	305	364	751	41	-33	-65	-98	1-3	2-6	3-9	5-2	6-5	16
0.0002	24	47	32	39	43	49	53	61	66	77	84	97	105	120	131	151	165	187	208	240	263	309	366	758	41	-33	-65	-98	1-3	2-6	3-9	5-2	6-5	16
0.0001	19	52	37	34	45	51	56	64	70	80	88	102	110	126	138	158	173	197	218	254	277	325	385	797	43	-33	-65	-98	1-3	2-6	3-9	5-2	6-5	16
0.00008	24	47	29	42	50	57	63	72	79	90	100	115	124	142	155	179	195	222	246	285	316	365	434	901	49	-27								

Operators Notes

SECTION TWO - INSTALLATION AND PRELIMINARY CHECKS

2.1 Installation and Lifting

In planning the siting of a machine consideration should be given to the space required for chip removal, bar loading and servicing, i.e. centre-shaft removal. Dimensions of suitable lifting bars for use with a crane are shown on the Foundation Drawing fig.2.1. Slings must not lie against the machine during hoisting. The position of the slings (in tension) must be examined on the rope before the full weight of the machine is lifted.

Where a crane is not available, the machine may be moved by "wedge" truck or rollers and continuous machined surfaces are provided on the underside of the machine tray to facilitate the operation. Rollers must be longer than the machine tray width.

Careful handling of the machine will ensure accurate alignment.

2.2 Machine Foundation

The machine should be installed on a level and stable foundation in order to ensure accurate alignment is maintained. A concrete base is recommended, that it provides the most suitable foundation because of its stability and because it is less prone to distortion when laid down in adverse soil conditions.

The actual depth of concrete base must be determined to suit the prevailing soil conditions, which must be capable of supporting the machine, its ancillary equipment, its tooling and the concrete base itself.

The soil should be consolidated with crushed rock, pebbles and stones.

2.3 Levelling the Machine and Sundry Requirements

With the machine in position on the factory floor, adjust its level using the jacking screws provided in the machine tray. It is recommended that steel plates be placed between the floor and the screws. Longitudinal and lateral alignment levels can be checked with a precision spirit level on the facings provided at both ends of the machine tray and on top of the spindle drum housing, see Foundation Drawing fig.2.1. Wedges should be placed at the positions shown.

Foundation bolt holes are also provided for use where required, the bolts being embedded in the floor approximately 5in. (125mm).

Where not bolted-down, machines can be grouted or cemented by any shop approved method.

The stock carriage tube assembly (weight: 1.016 tons) should be lifted into position and the stand fitted.

The stock carriage indexing gears must be assembled with the meshing marks together, as shown in fig.2.3, and the cover segments fitted.

Steel plates should be placed under the screws in the stock carriage stand. Initial alignment can be made by sighting through the tubes and then by adjusting the position of the stand to obtain a uniform clearance all round between the cover segments and the carriage indexing gear. The holding-down bolts must be cemented and secured.

The bar feed spring and cover is fitted as shown in fig. 4.6. The splash guard brackets and splash guards may also be assembled.

Fig.2.1 Foundation Drawing 500Y 50C

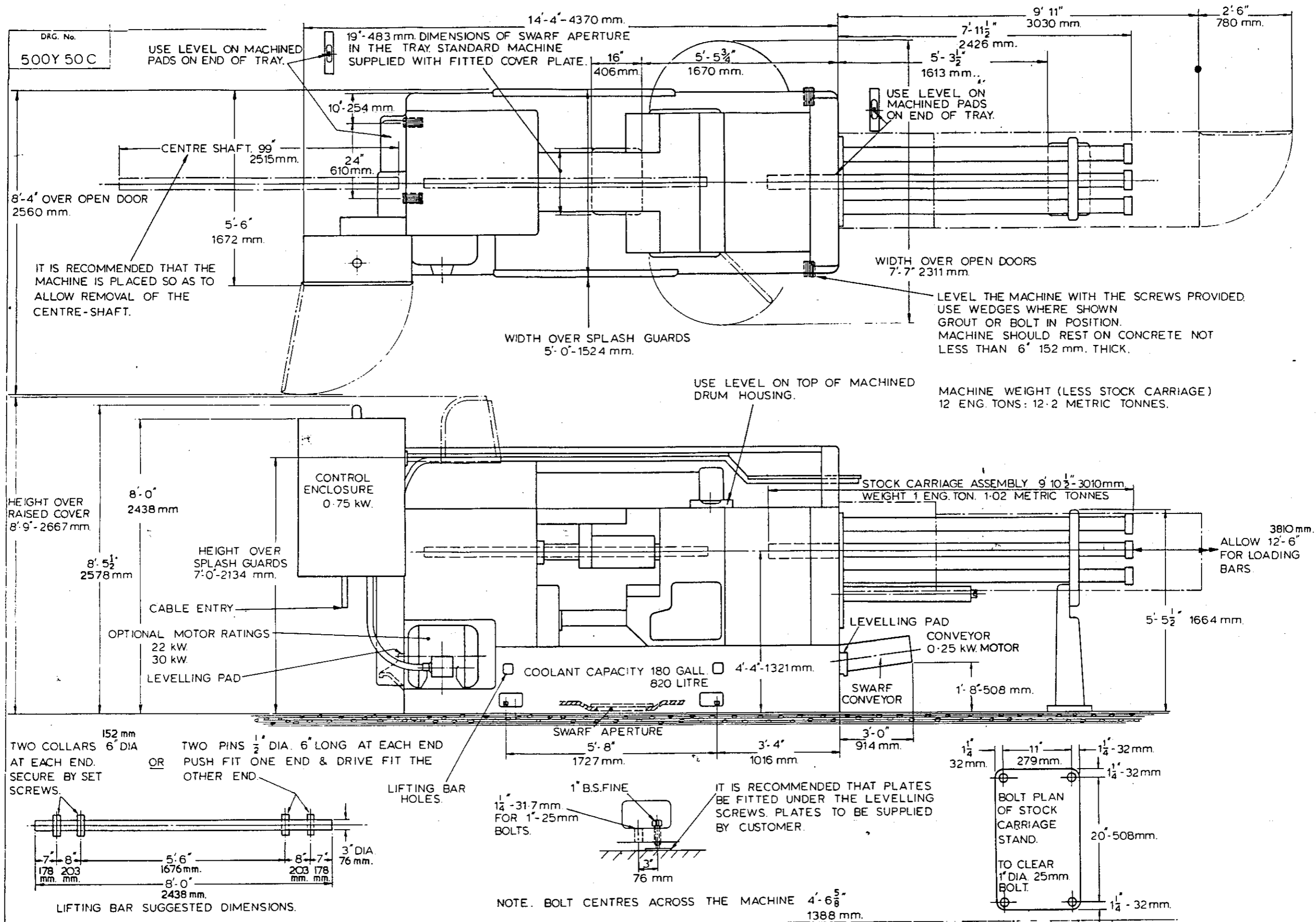
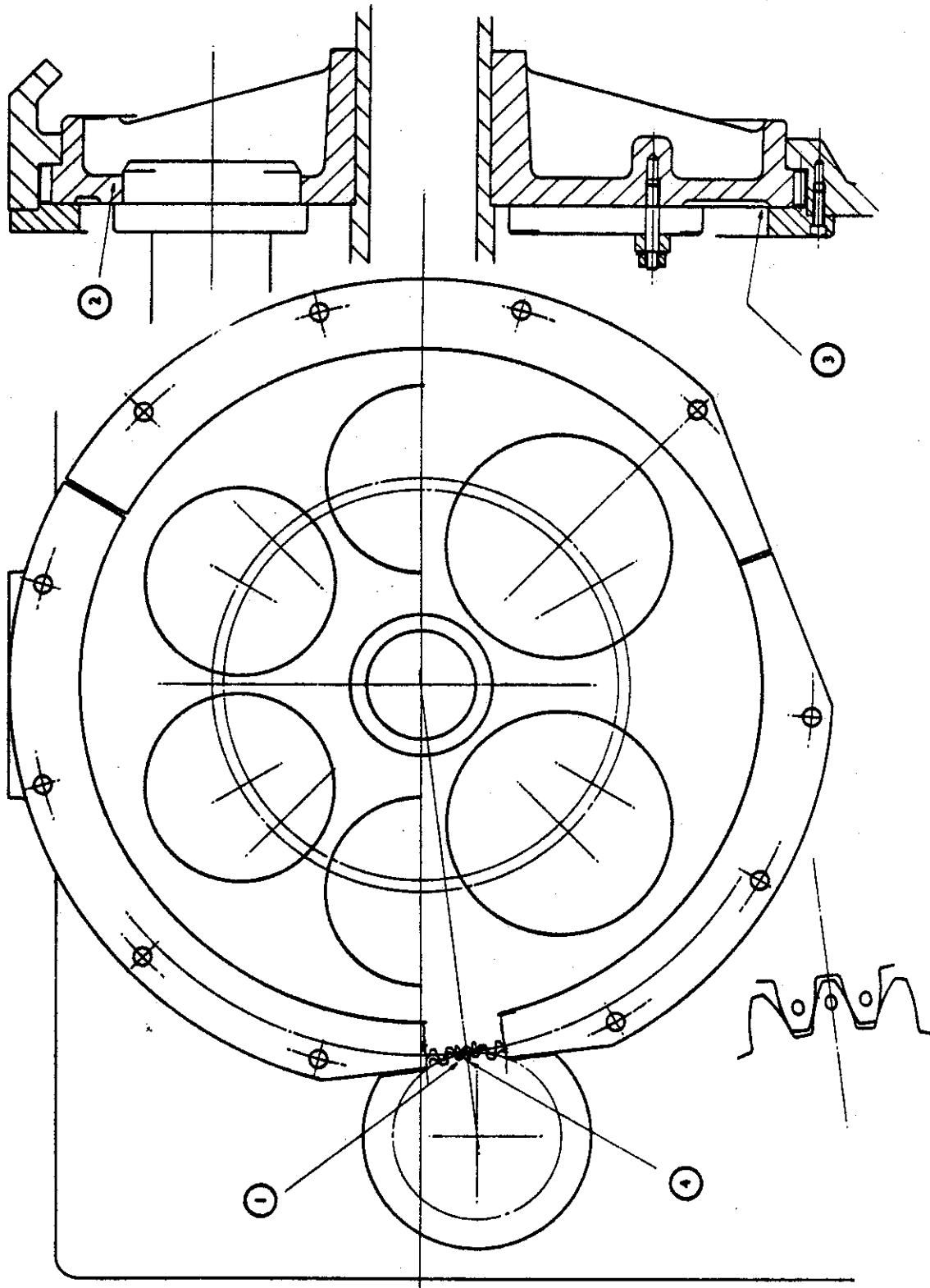

Fig.2.3 Meshing Marks

1. Marked teeth to mesh as shown, when stock carriage is assembled.
2. Stock carriage indexing gear.
3. Check clearance between stock carriage indexing gear and cover.
Segments must be equal all round if the stock carriage is correctly lined up to machine.
4. Machine to be indexed until marked tooth of small gear is on centre line as shown at completion of indexing. This is to be done before fitting stock carriage.

Fig.2.3 Meshing Marks



500Y 61

All protective grease should then be removed from internal and external parts with paraffin or white spirit, taking care not to contaminate lubrication oil with protective grease and cleaning fluid residue.

Coolant strainers, work baskets, chutes etc., can then be placed in position, see fig. 2.4.

The swarf conveyor, if supplied, may also be fitted, see fig. 2.5 for the positioning of the swarf deflection chutes and electrical connection etc.

The machines have an aperture in the tray floor for use with underground disposal systems, where all swarf and coolant passes through the tray and is conveyed to a collection depot. Machines are supplied with a cover plate fitted to the aperture and this should be unscrewed during installation in factory shops using the system and connections made to the centralised coolant supply.

2.4 Electrical Equipment

It is impossible in a general handbook to cover the electrical specification on each machine supplied, since the electrical equipment on each machine can vary considerably. Reference should be made to the wiring diagrams and other information forwarded with each machine.

Fig. 2.1 shows the position of the incoming cable entry. The standard electrical control enclosure includes an isolator/main circuit breaker. It is only necessary to connect the line and earth. The rotation of the main motor should be clockwise when viewed from the pulley end. Before starting the main motor, read through the procedure in section 2.6.

The wiring diagram is included and can be found in the data pocket inside the door of the control enclosure.

Careful attention should be exercised in order to ensure that all the motor circuit breakers and the thermal overload heaters are correct for the electrical supply; this is important when dual voltage motors are supplied.

Supply voltage to the fluorescent tooling area lighting is 110V 50Hz ie, the control circuit voltage. The voltage is increased to 240v, through a transformer mounted in the lighting unit, to ensure efficient "starting".

The above details are checked by Wickman Bennett before despatch, but should also be rechecked at customer's site.

The swarf conveyor motor starter is fitted in the control enclosure and the relevant push buttons and pilot lights are mounted on the pendant control station. Provision is also made for fitting an auxiliary motor starter when required.

On Star-Delta equipment, operation of the timer should be checked for a time lag of approximately 15 seconds and all starter gear should be checked for freedom of operation.

2.5 Lubrication

The lubrication system has two separate parts with the two plunger pumps contained in the same unit and chain driven from the constant

Fig.2.4 Strainer Box & Weir

1. Coolant pump intake pipe
2. Strainer box
3. Weir

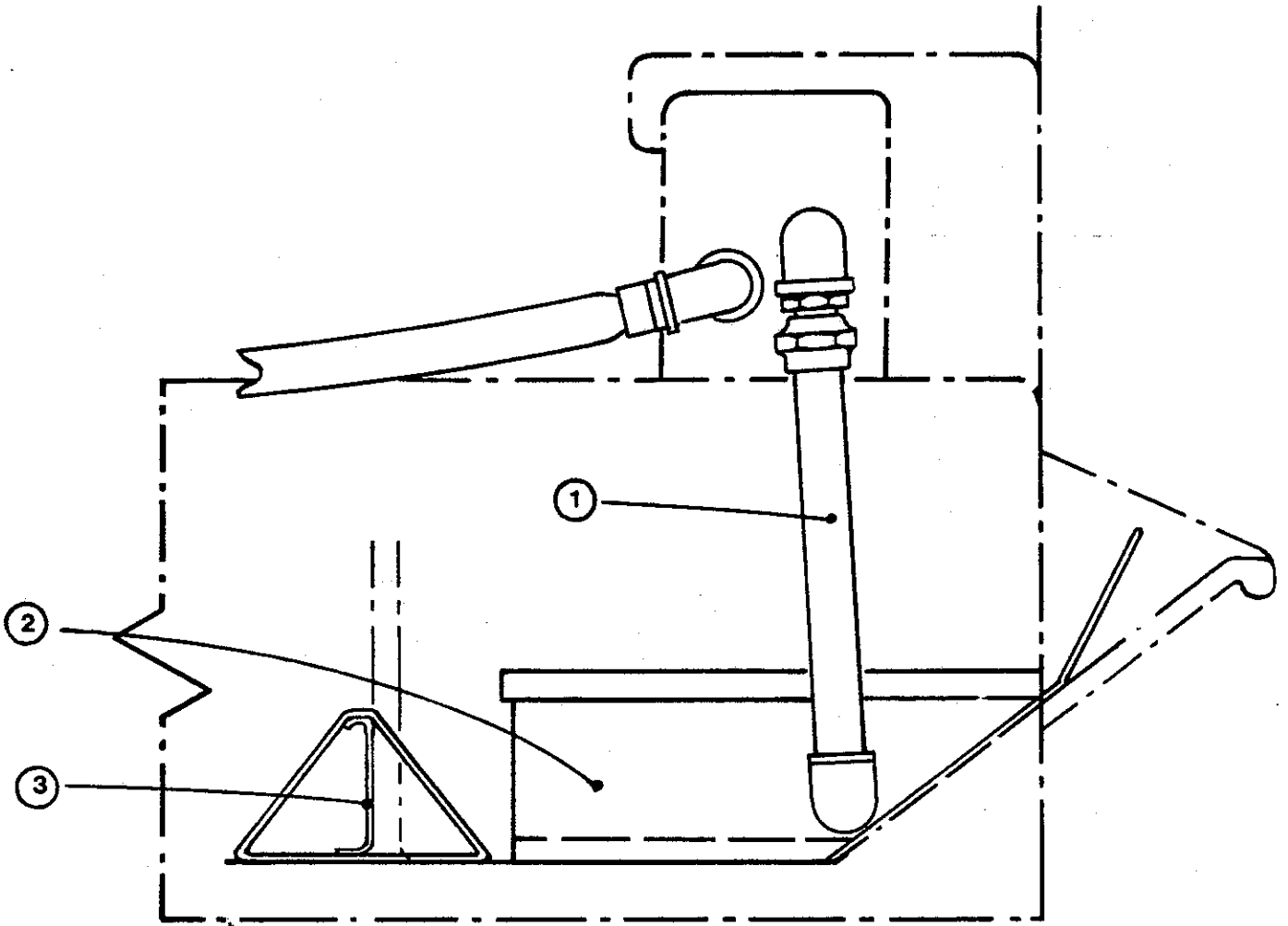
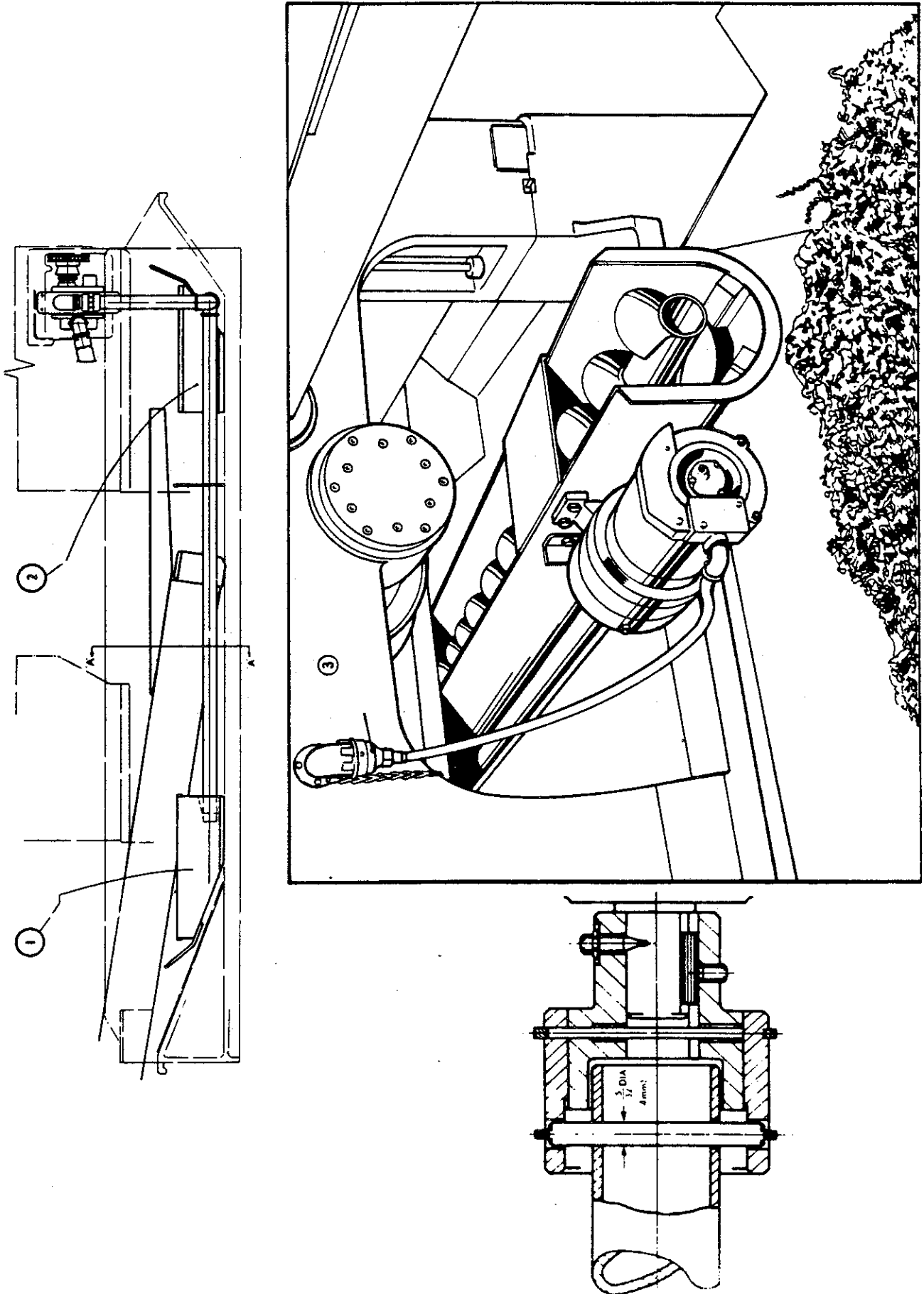

Fig.2.5 Swarf Conveyor

1. Coolant strainer box.
2. Basket to collect fine swarf.
3. Niphan plug and socket.



speed shaft. Access to the unit is through a cover on the lower face of the motor end of the main drive housing. Chain adjustment is to be found in the Maintenance Manual.

One side of the pump raises oil from the main drive housing sump and passes it through the lower Purolator filter to distributors which supply all points in the main drive housing. The circuit contains a pressure relief valve set at 10-15lbs/sq inch (0.703-1.055kg/sq cm), the excess oil being fed to the upper camshaft oil bath. The bath supplies a number of drip points, and should be kept clean of dirt and grease. A strainer box fitted to the pump intake must not be allowed to become choked. Examine twice a year and clean the sump if necessary. Check the oil level in the sump through a sight glass situated in the front of the main drive housing and fill at regular intervals.

The other side of the pump unit draws oil from the tank in the beam through the upper Purolator filter and passes it to sight feed headers for the spindles and to distributors for drum housing and cross slide feeds. The circuit contains a pressure relief valve set at 10-15 lbs/sq inch (0.703-1.055 kg/sq cm.) and contained in a block. When a "Flush" button in the block is pressed, the relief valve is blocked and a surge of oil is passed to the spindles and drum housing feeds. The "Flush" button should be pressed daily on machine start up.

Oil in the drum housing should be maintained to the level indicated on the rear inside face of the drum housing. Keep clean of grease and soluble coolant contamination.

A priming plug is provided on the Purolator housing for filling or for releasing air locks. Purolator handles should be turned clockwise two or three turns each day to clear the element of foreign matter. The units should be removed twice a year and the element cleaned with paraffin and a soft brush. Use a solvent on gummy deposits.

An oil chart at fig. 2.6 specifies the I.S.O. standards for all the lubricants used on the machines.

Fill all grease nipples with grease, etc., as indicated on the chart fig. 2.7. Use ball bearing grease sparingly in the spindle nose labyrinth seal nipples.

Concerning Lubrication

- (a) Check all oil levels in tanks and sumps. They must not fall below the levels indicated.
- (b) Frequent checks of the spindle sight-feeds are necessary; also check that the main drive oil is circulating.
- (c) Turn Purolator filters daily: apply oil gun to all nipples and oil parts not served by the automatic system.

Fig.2.6 Summary of Lubricants

Wickman Oil Grade	1	2	3	4	5
Application	Light Spindle Oil	Air Line Lubrication for Cold Climates	Air Line Lubrication for Warm Climates	Centralised Lube. Air Line Lub'e Hyd. syst. Gen.Lub'e for Cold Climates	General Lubrication Centralised System for Warm Climates
B.P	Energol HL 40	Energol HL 50	Energol HL or HLP 65	Energol HLP 80	Energol HLP 100
CASTROL	Hyspin AWS 10	Hyspin AWS 22	Hyspin AWS 32	Hyspin AWS 46	Hyspin AWS 68
CENTURY	P79A	P313	PWLA	PWLB	PWLC
DUCKHAMS	Zircon 1	Zircon 3	Zircon 4	Zircon 5	Zircon 6
ESSO	Nuto H36	Nuto H40	Nuto H44	Nuto H48	Nuto H54
GULF	Harmony 34AW	Harmony 40AN	Harmony 43AW	Harmony 48AW	Harmony 54AW
MOBIL	Velocite oil No 6	Velocite oil No 10	DTE oil light or DTE 24	DTE oil med. or DTE 25	DTE oil heavy med. or DTE 26
PETROFINA	Cirkan 15	Hydran 21	Hydran 31	Hydran 31	Hydran 37
SHELL ISO VG NO	10	22	37	46	68
TEXACO	Spintex 60	Spintex 100	Rando HD.A	Rando HD.B	Rando HD.C
VAUGHAN	KSO 5L	KSO No.1	Evco Med. Hyd. or Hydrodrive HP 150	Evco Heavy Hyd. or Hydrodrive HP 200	Evco Extra Heavy Hyd.or Hydrodrive HP 300

Where alternative grade references are given it is recommended that the lighter grade (lower number) is used unless oil consumption is excessive.

For Slideways Grade 5 is suitable for use with oil-base coolants and Grade 7 for use with water-base coolants.

Wickman Oil Grade	6	7	Wickman Grease Grade	1	2
Application	Reduction Units (Swarf conveyor)	Slideways		GREASES	
B.P	Energol CS 300	Energol HP 20-C		Electric Motors	Spindle Nose Cap
CASTROL	Alpha 417	Magna BD		Ener Grease LS3	Ener Grease LS3
CENTURY	WLP	428AP		Spheerol AP3	Spheerol AP3
DUCKHAMS	Galrex 9	Adglide 6		Lupus 3	Lupus 3
ESSO	Esstic 78	Febis K73		Admax 13	Admax 13
GULF	Mechanism LP 85	Gulway 52 or Slidway 52		Beacon 2/3	Beacon 2/3
MOBIL	DTE oil BB	Vectra Oil		Gulfcrown No. 3	Gulfcrown No. 3
PETROFINA	Solna 58	Artac 37		Mobilplex 48	Mobilplex 48
SHELL ISO VG NO:	220	68 or 320		Marson HTL 3	Marson HTL 3
TEXACO	Regal GR & O	Way Lubricant D		Alvania R2 & R3	Alvania R2 & R3
VAUGHAN	Cosmolub- ric EHC	Way Lubricant		Regal Starfal Premium 3	Regal Starfal Premium 3
				Evco BB No. 3 Grease	*Cosmolube Grease/No4 Grease

REMARKS:

For Slideways Grade 5 is suitable for use with oil-base coolants and Grade 7 for use with water-base coolants.

* Re: Cosmolube No. 4: Use sparingly and only in nose cap seals.

2.7 Lubrication Points

Key

1. Bar feed bobbins
2. Spindle sight feeds
3. Spindle nose seals
4. Flush button: press to flush daily on starting machine
5. Stroke adjusting blocks
6. Spindle caps (grease 1 nipple per spindle)
7. Cut off slide
8. Intermediate slide
9. Keep stock carriage spring liners well greased
10. Lower cross slide
11. Lower cross slide
12. Roller pin

Frame 5, 8-Spindle
Bar, Operators

- 13.A. Grease nipples, twice weekly, use heavy oil (grade 7)
- B. Grease nipples, twice monthly, use heavy oil (grade 5)
- C. Grease nipples, monthly, use ball bearing grease (grade 2)
- D. Mineral oil used should have a viscosity of 400/500 Redwood at 70deg.F (Engler 15-5/20-5 at 20deg.C)
14. Roller pin
15. Lever boss
16. Indexing gear
17. Locking shaft
18. Fill sump with mineral oil: check twice weekly
19. Bar feed bush
20. Collet bush
21. Slide base
22. Fill sump with mineral oil: check twice weekly
23. Fill oil tank with mineral oil: check daily
24. Bar stop bracket
25. Slide base
26. Control bracket
27. Motor: grease every six months
28. Purolators: turn daily
29. Priming plug
30. Cam drum
31. Bar feed bracket
32. Cam drum
33. Geneva roller
34. Bracket
35. Collet slide
36. Collet roller
37. Bar feed slide
38. Camshaft bearing

Fig.2.7 Lubrication Points

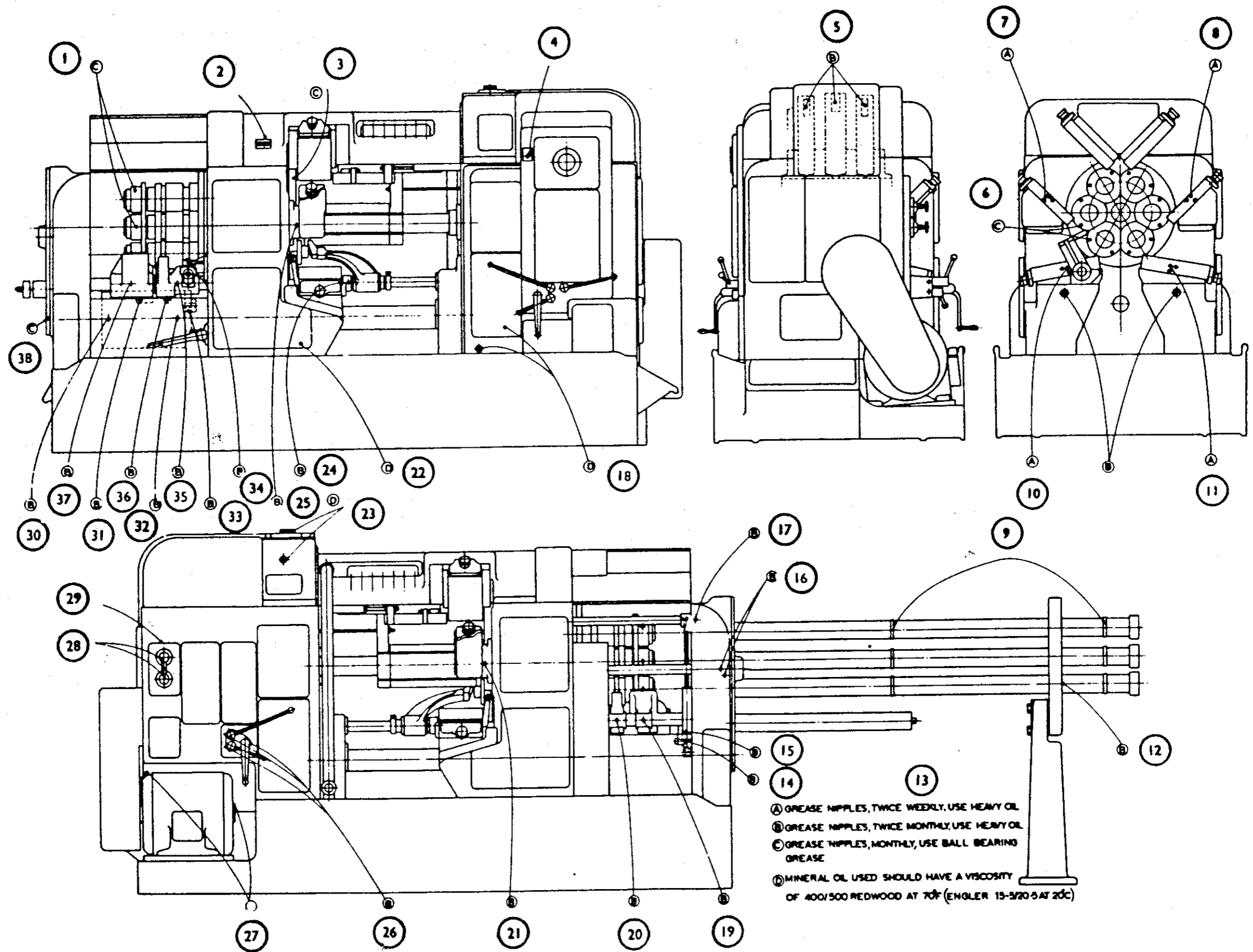

2.6 Procedures before Starting the Machine

Before starting the machine the following procedures should be carefully carried out:-

- 1) Ensure that all protective grease has been cleaned off the machine and that the oil tanks in the beam, the sumps and the tray are clean.
- 2) Fill (a) the oil tank in the beam, (b) the sump of the main drive housing and (c) the sump of the drum housing to the gauges.
- 3) Apply a grease gun to all the grease nipples as shown on the lubrication chart, fig. 2.7 Use the specified oil, see the recommended Oiling Chart, fig. 2.6.
- 4) Either fill the tray with coolant (approximately 180 gal ,820 litres will be required) or remove the coolant pump chain, if this has not been done before despatch, as running dry may cause the coolant pump to seize. Place the strainer box, weir and tray plate in position as shown and check that all the coolant taps are closed.
- 5) Set the speed range change sliding gear in neutral and the feed clutch in brake. (See fig.4.5)
- 6) Check the direction of rotation of the motor (clockwise looking on pulley). Read the section titled 'Operator's Controls'.
- 7) Run the motor to check that the lubrication system is working. On starting, the "Flush" button should be pressed to flush the spindle drum system with oil. See that the spindle sight feeds are functioning correctly. Remove the cover over the speed pick off gears and see that the main drive lubrication system is working by observing the oil pipes feeding the pick off gears.
- 8) Check that the collets and feed fingers are correctly fitted. Disengage the collet operating roller and place the bar feed pusher plate in the down position.
- 9) Test the freedom of the spindle drum and the tool slides and the clearance of any toolholders and attachments fitted, by handwinding the machine through a complete cycle.
- 10) Re-engage the speed range change sliding gear.
- 11) With the machine tray filled with coolant the machine can then be toolled, tooling proven and made ready for running on production. See fig 2.5 for machines fitted with a Swarf Conveyor.

Operators Notes

SECTION THREE - OPERATOR'S CONTROLS

3.1 Controls

The machine controls fall basically into two groups:-

- (I) The electrical hand operated switches in the front and rear pendant control panels.
- (II) The manual controls.

3.2 Electrical Controls

The electrical controls in the front pendant control panel are shown in fig. 3.1. They comprise of rotary selector switches and push buttons.

The selector switches cover the following functions:- start/jog selection for the main motor, feed and the swarf conveyor, coolant-start or dry run, feed trip-set up or run and control-front/rear of the machine.

The push buttons have the following functions:- control on and control off, main motor start, feed start, conveyor start, Reset lubrication 1 and 2, main motor jog, feed jog, conveyor jog reverse, main motor stop, feed stop, conveyor stop and emergency stop.

The rear pendant control panel is shown in fig.3.2. The pertinent functions necessary for operating the machine when standing at the rear are embodied in the control switch gear in this panel and duplicate certain controls contained in the front panel.

In addition certain function indicator lights are included in both pendant control panels. All the indicator lights, selector switches and push buttons carry the inscription of their functions.

The front and rear selector switches are two position switches and both must be at the same setting, either "Front" or "Rear" before the appropriate start or jog button can be used to start the main motor. Setting both selector switches to the "Front" position renders the rear panel, with the exception of the emergency stop, main motor stop and feed stop push buttons, inoperative. Likewise, when both selector switches are set to "Rear" position all the pertinent push buttons of the rear panel duplicated in the front panel, are rendered inoperative.

The "Emergency" stop button when pressed will shut down every function on the machine.

The "Control" on and off buttons in the front pendant control panel energise or de-energise the control panel circuitry.

Fig.3.1 Front Pendant Controls

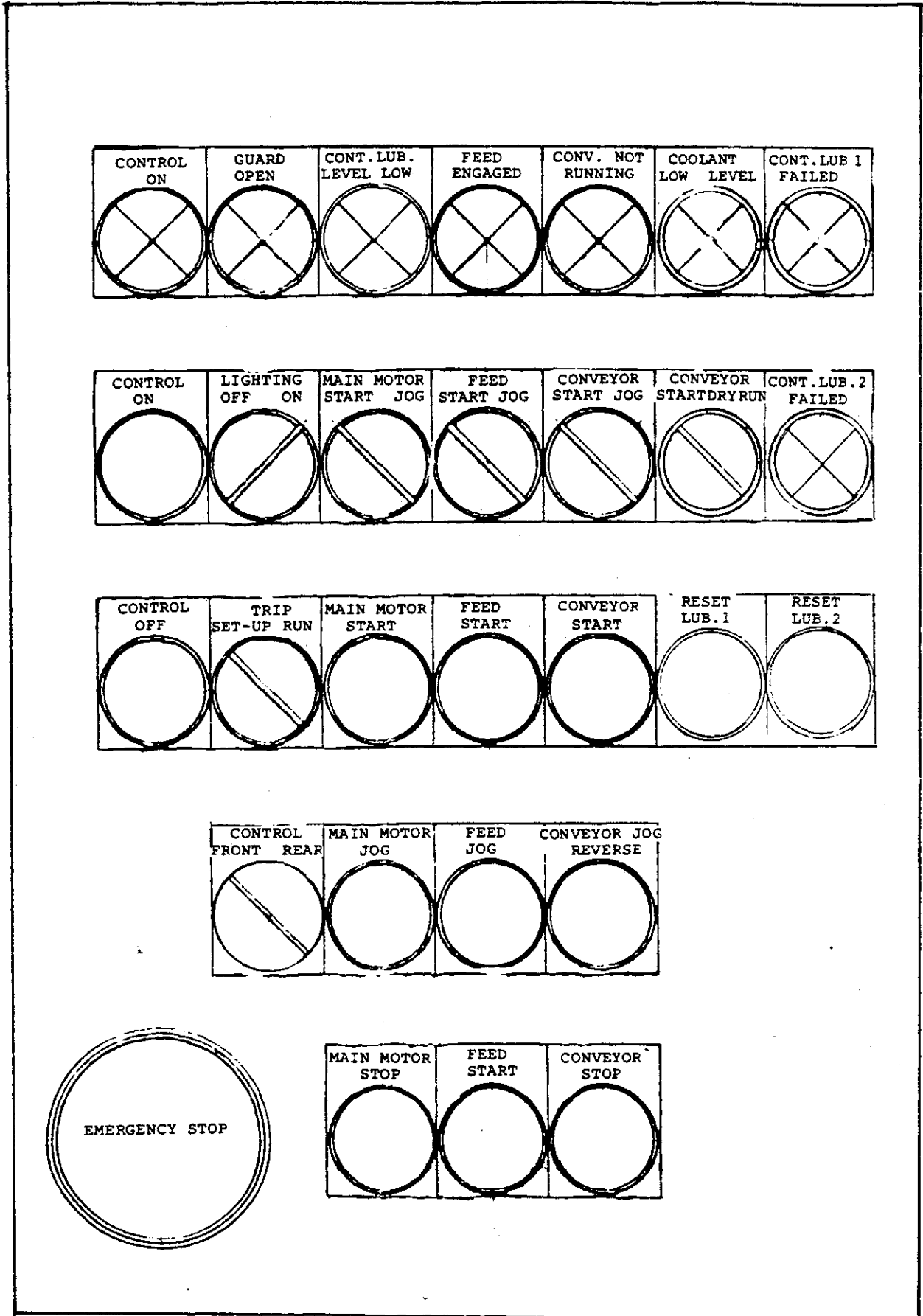
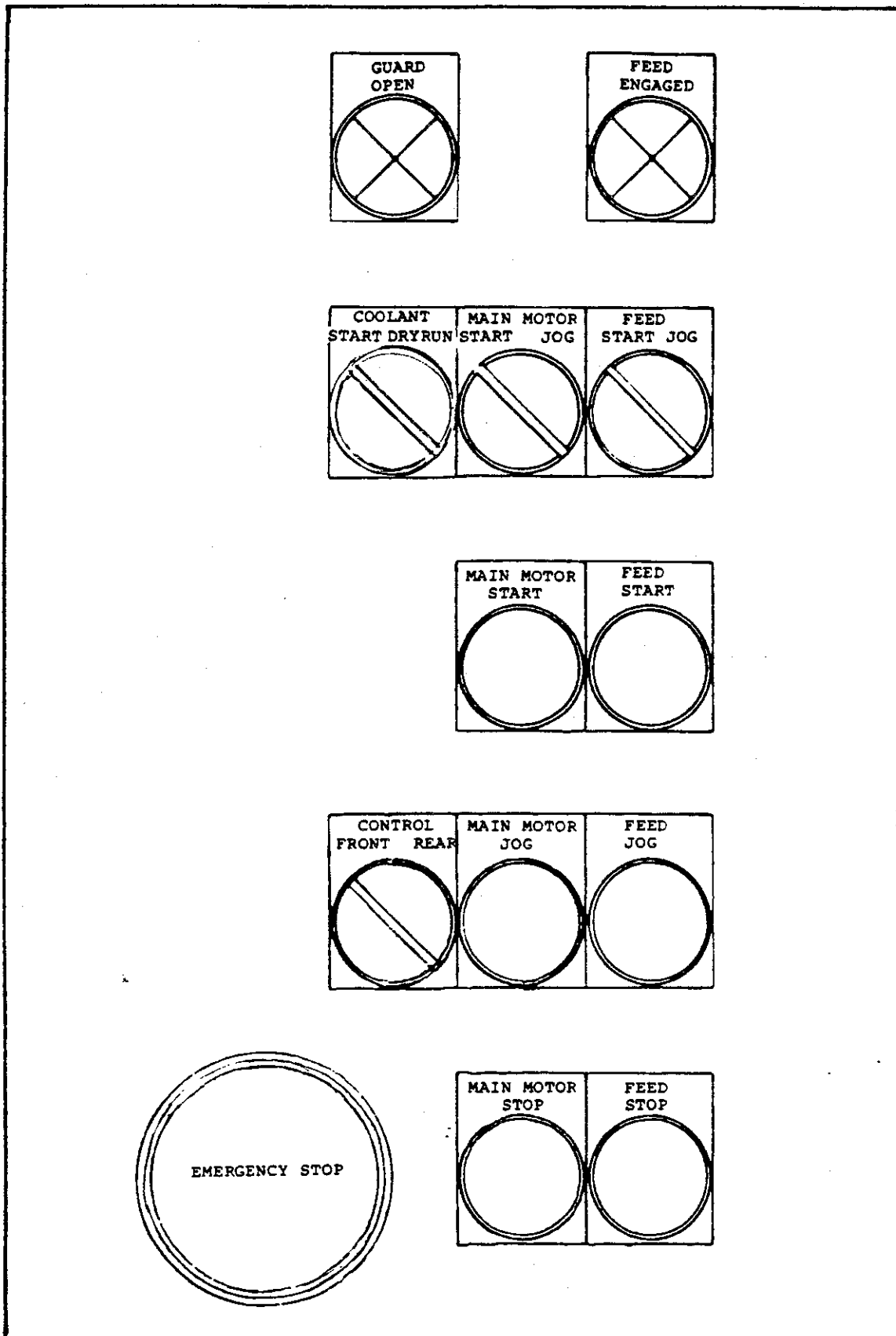

Fig.3.2 Rear Pendant Controls



3.3 Manual Controls

The manual controls comprise:-

- (i) The feed shaft dog clutch operating lever.
- (ii) The hand-wind engagement lever.
- (iii) The hand-wind shaft and hand wind crank.
- (iv) The index clutch lever.
- (v) The collet hand operation lever.
- (vi) The bar feed shoe disengagement knob.
- (vii) The collet operating shoe disengagement mechanism.

Concerning Manual Controls

- (a) After starting the machine allow a lapse of a few seconds before engaging the electro-magnetic feed-clutch in order to enable the electrical control gear to change from "star" to "delta" and also to ensure all working parts are adequately lubricated.
- (b) When a slipping clutch has disengaged, locate the cause of the overload and correct the condition before re-engaging the clutch and re-starting the machine.
- (c) Remember you cannot handwind the machine through the feed motion if the tooling set-up includes a threading operation, unless the necessary steps are taken to ensure that the tap or the diehead do not cut a thread.
- (d) Test all clutches by hand for adjustment. They should not be set so slack as to cause slip or too tight, and excessive pressure should not be required to operate them.

Handwinding the Machine:-

Handwinding the machine through its cycle of operations is necessary when checking the freeness of operation of the spindle drum when indexing and the machine slides through their cycle of operations, and also for setting purposes.

Handwinding can be achieved by engaging the manual controls 'i', 'ii' and 'iii' in the following order:-

- (i) The feed drive shaft dog clutch operating lever, duplicated on both operating sides of the machine, should be raised to disengage the feed drive shaft dog clutch and electrically render the electro-magnetic feed clutch inoperative in order to prepare the circuit so that when the hand-wind is engaged, the feed drive shaft can be rotated manually. The action of raising the operating lever also releases the mechanical interlock which prevents the hand-wind from being engaged when the machine is running on production.
- (ii) The hand wind engagement lever, situated beneath the feed shaft dog clutch operating lever, and also duplicated on both operating sides of the machine, is pushed in a downwards direction to engage the hand-wind gearing and electrically energise the electro-magnetic brake to release same for hand-winding. The foregoing is only possible when electrical power is energising the machine. When electrical power is not available it is necessary to release the electro-magnetic spring applied brake manually by means of the tensioning screws; see the instruction plate on the brake cover.

- (iii) When the hand-wind gearing has been engaged, the hand-wind crank, which is detachable and can be fitted to and dogged with the hand-wind shaft on either operating sides of the machine, provides the means of hand winding the machine. The hand-wind crank makes 180 turns for one complete cycle of the camshaft; the camshaft moving through 2 degrees for each revolution of the hand wind crank.

Index Clutch Operating Lever:-

- (iv) The raising of the index clutch operating lever and allowing the plunger handle to drop into a retaining hole in the bracket, renders inoperative the drum indexing, collet operation, bar feed and drum locking mechanisms. By this means it is possible to repeat a cut as many times as required during setting.

An interlock is fitted so that the clutch cannot be disengaged during the indexing of the spindle drum. The clutch is spring loaded into engagement and due to the shape of the dogs, will drop back into place only at the correct time. To ensure constant oil supply reaches all of the spindles, it is inadvisable to run the machine for long periods with the indexing mechanism disengaged.

Collet Hand Operation Lever:-

- (v) The collet may be opened and closed by hand in station 1 by placing the hand lever provided into the collet operating lever. This must be raised to engage the operating mechanism. A gap in the cams is provided to allow for hand operation when bar loading. A stop is provided for the collet operating slide to enable the collet closing mechanism to close to a constant position, after hand or cam operation.

The Bar Feed Shoe Disengagement Knob:-

- (vi) The bar feed may be disengaged in station 1 by turning a knurled threaded knob, mounted on the bar feed slide, to withdraw the bar feed shoe out of engagement with the bar feed tube. The withdrawal of the bar feed shoe renders the bar feed inoperative.

The Collet Operating Shoe Disengagement Mechanism:-

- (vii) On this range of machines the collet operating shoe in station one is not withdrawn to make collet opening and closing inoperative since it is not an essential requirement. The collet operating shoe is spring loaded as a safeguard should the collet operating sleeve index out of position. The collet operation mechanism can be rendered inoperative by withdrawing the roller carrier after unlocking a pad bolt.

Operators Notes

SECTION FOUR - OPERATING ADJUSTMENTS AND PROCEDURES

4.1 Chanding spindle speed gears

An example of the use of the speed and feed plate and charts is shown on pages 17 to 19.

Access to the spindle speed pick off gears "A" and "B" fig 4.1 can be gained by removing the cover on the main drive housing situated above the belt guard.

Access to the high-low range change, (fig.4.2) can be gained by removing the cover next to the Purolator on the rear of the main drive housing.

The speed and feed plate on the front of the main drive and the charts, pages 17 to 19 show the gears "A" and "B" in the top column and the spindle speed N/min for the high range "CC" and the low range "DD".

The two gears "A" and "B" are keyed on taper shafts and held by slotted washers and hexagon nuts. Unscrew the nuts sufficiently to remove the washers and slide the large gear extractor (573 x 117 supplied in the tool kit) over the groove in the gear boss. Tighten the extractor bolt against the end of the shaft to withdraw the gear. One gear should be just withdrawn enough to be free on its taper and then the other gear completely removed. This ensures that the gears remain mesh and prevent the shaft from turning whilst using the extractor. A gear that is very tight will free if the extractor bolt is given a sharp tap with a mallet. Gears and shafts to be cleaned before replacing.

In order to change the high-low range, release the pad bolt and slide the glut and gears into the position required, re-clamping the pad bolt. Slide to the right for the high range "CC" and to the left for the low range "DD".

Fig.4.1 Spindle Speed Pick-Off Gears

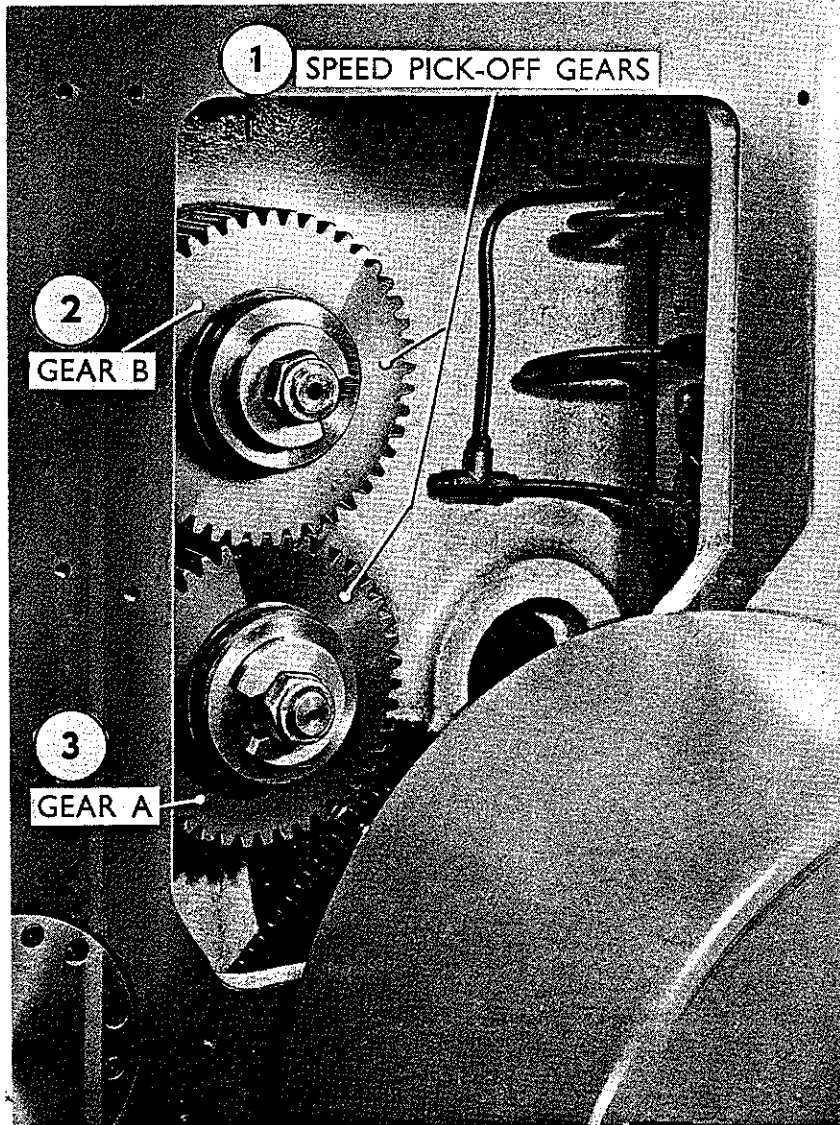
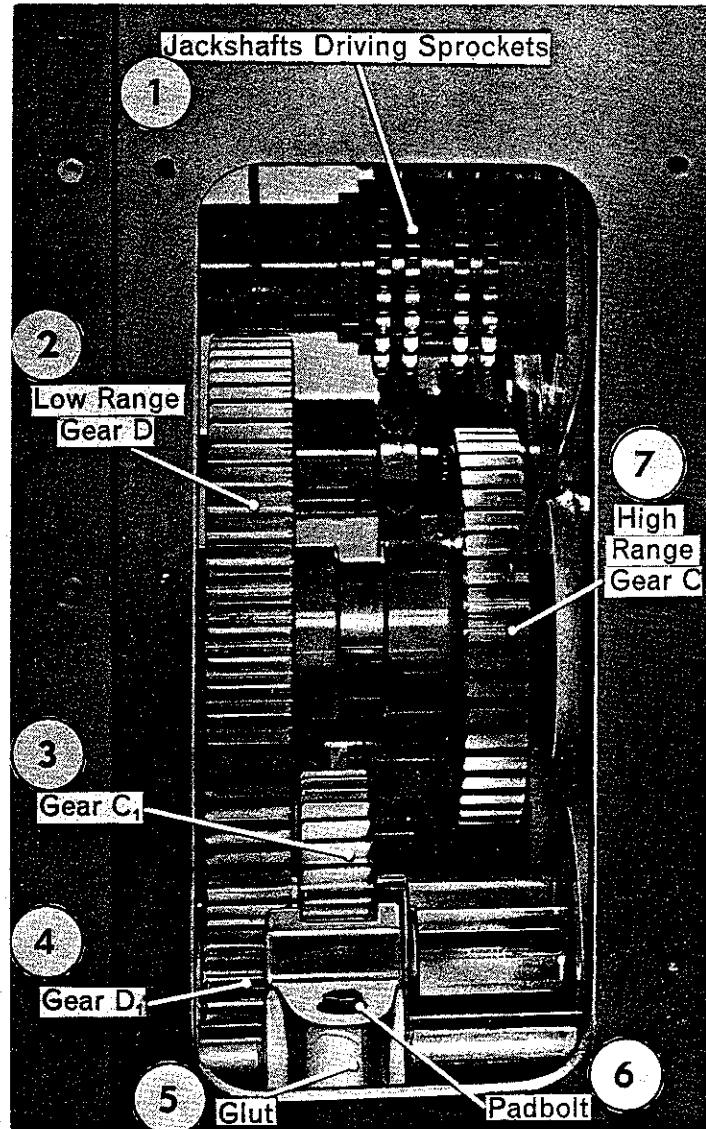

Fig.4.2 High-Low Range Change Gears



4.2 Changing Feed Gears

Access to the feed gears "F" and "H" can be gained by removing the cover on the end face of the main drive housing, motor end, adjacent to the speed pick off gear cover, refer to fig.4.3.

Access to the feed gears "J" and "K", fig. 4.4, can be gained by removing the upper cover on the front of the main drive housing nearest to the spindles.

The feed and speed plate or charts show the feed pick off gears, "F", "H", "J" and "K" in the vertical columns on the left hand side, and the cycle time "T" in seconds to the middle.

The four feed gears are keyed on taper shafts and held by washers and nuts. The gears can be changed in the manner described for the speed gears, using the small extractor supplied in the tool kit. Partially loosen all four gears before removing the nuts, washers and gears from the shaft.

Fig.4.3 Feed Gears 'F' & 'H'

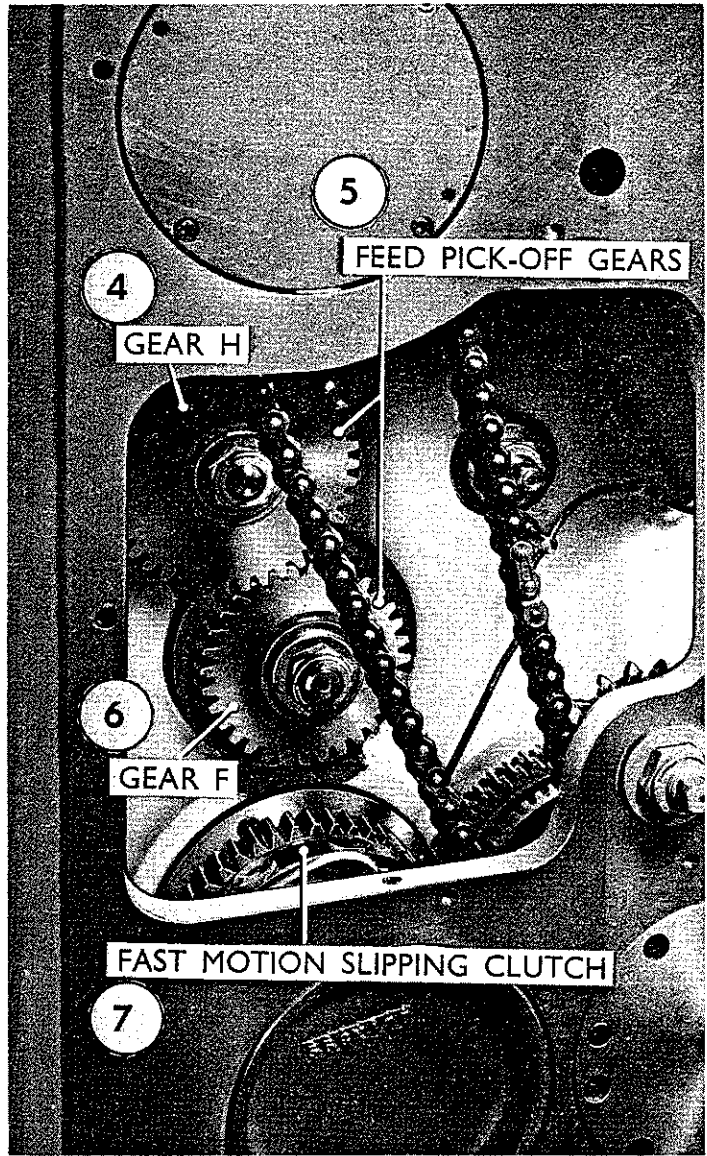
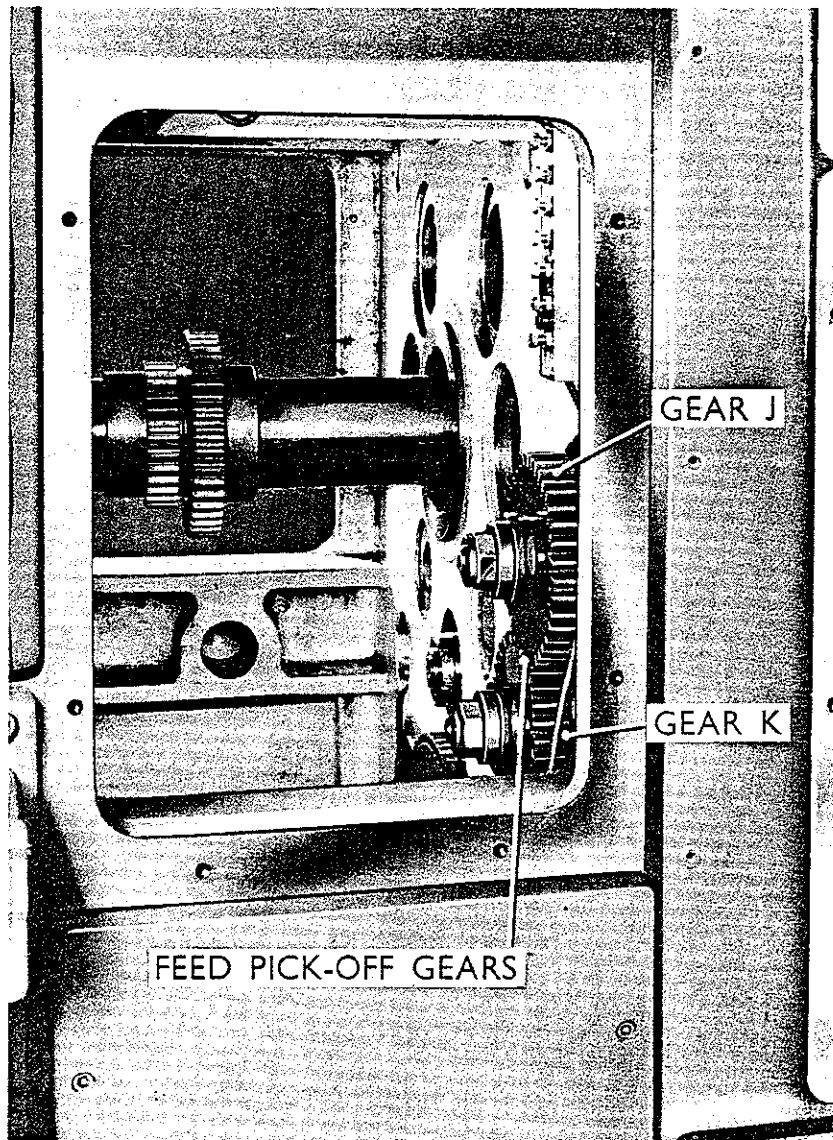

Fig.4.4 Feed Gears 'J' & 'K'



4.3 Changing Feed Fingers and Steady Bushes

The feed tubes should be withdrawn from the 1.3/4"-8, 1.3/4"-8S and 50mm-8 arranged for single bar feeding at station 1 where the collet hand operation is fitted, the machine being stopped just after indexing with the collet open.

In order to obtain extra clearance, place the spacing block (item 573 X 113 in the tool kit) between the stop collar on the front guide bar and the bar feed slide. It should be placed in position when the bar feed slide withdraws.

Unscrew the hexagon nut clamping the pad holding the stock tubes in place, turn the pad clear and withdraw the stock tube approximately 3 feet (914mm). Use bar feed disengage knob to withdraw the bar feed shoe clear of the feed tube bobbin.

Loosen the three nuts holding the stop plate to the centre stop between the spindles and partially turn the plate to permit the withdrawal of the tube assembly from the machine. Place the feed tube assembly on a 3/8in diameter rod held in a vice, through the holes drilled in the tube at the feeder end. This enables the feed finger to be unscrewed (left hand thread) with the wrench provided without distorting the tube. Gripping the tube in a vice will distort the tube and prevent the feed finger from being easily unscrewed. Refrain from using a mallet on the wrench to over-tighten when replacing the feed fingers. Feed fingers should be clean and the thread completely free from debris.

Steady bushes are held in the bobbin end of the feed tube assembly with a slotted locknut locked with another slotted locknut. Use the adjustable "C" wrenches to unscrew these nuts (left hand threads). See fig 4.5.

Fig.4.5 Feed Fingers & Steady Bushes

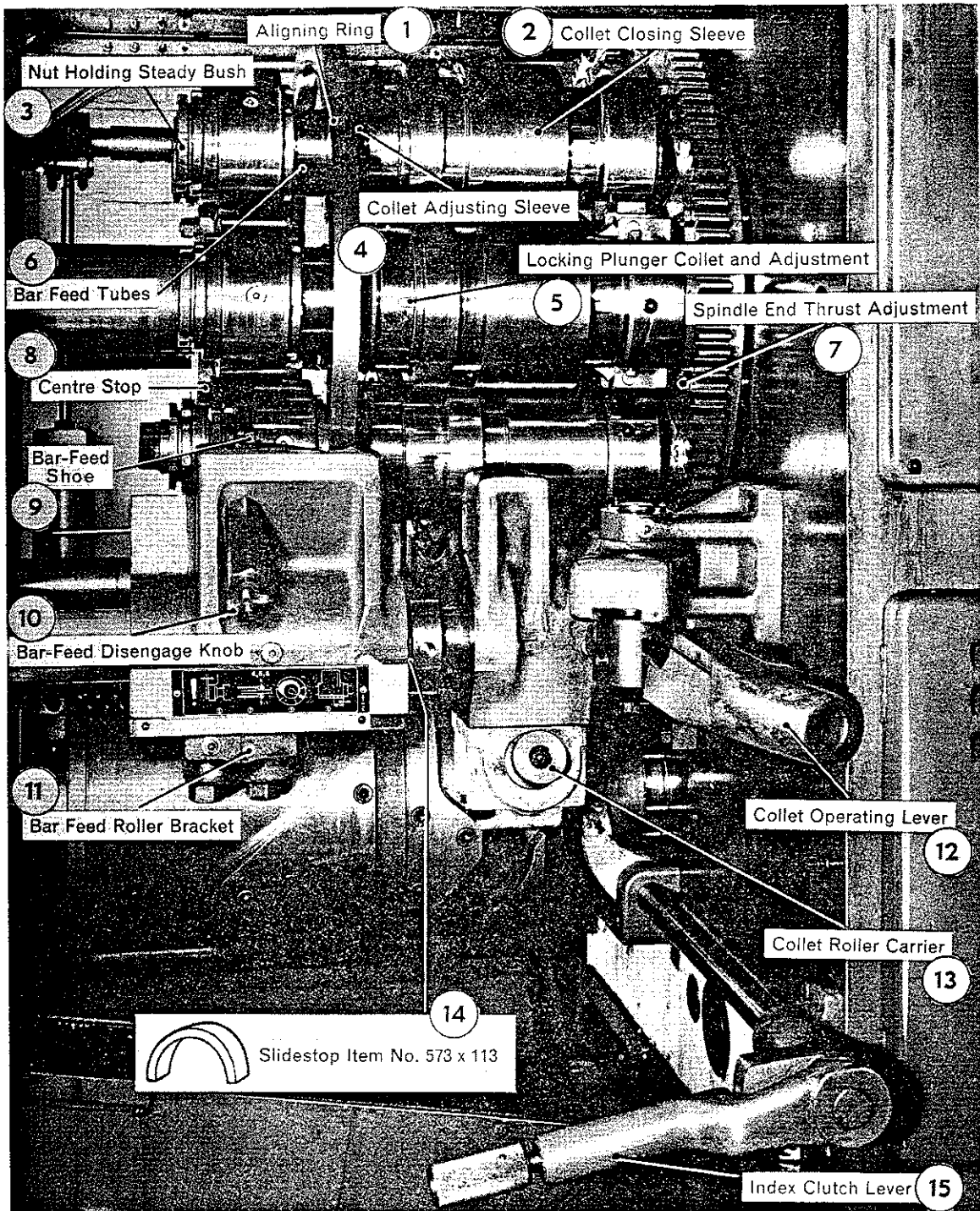

4.4 Changing Collets

Collets are changed by turning the one piece adjusting sleeve and tube until it is unscrewed from the collet (right hand thread) and withdrawing the collet past the location key in the spindle nose. A pin wrench (item 573X106) is provided to turn the adjusting sleeve. The collet adjustment is locked by a spring plunger locating in one of a series of holes in a flange on the sleeve. The plunger should be withdrawn and held out of engagement by sliding a small pin attached to the plunger into a retainer slot cut into the plunger housing.

Replacement collets should be well cleaned and each spindle nose seating examined and cleaned to remove all debris and coolant scum deposits before fitting each replacement collet on the spindle nose location key and screwing the adjusting sleeve into the collet. Feeder and stock carriage tubes should be replaced.

Before replacing bars in the feeders and finally adjusting the collet tension, set the bar feed stroke.

4.5 Setting Bar Feed Stroke

It is important when the bar feed stroke is to be increased, to adjust the centre stop to the maximum rear position. Use the "T" type wrench on the two 7/16in (11.1mm) square head locking screws in the centre stop.

Unclamp the two hexagon nuts below the bar feeder roller bracket, fig. 4.5 and move the bracket until the stroke required is indicated on the bar feed slide scale.

The same method is used for setting the bar feed stroke on the double bar feed machine, the difference in the arrangement being the extended arms on the bracket to operate the bar feed in stations 3 and 6 instead of station 1.

After moving the bracket to obtain the required stroke, re-clamp tightly in order to prevent slip and consequent short bar feeding. Handwind the machine until the slide is in the rear position and reset the centre stop with the stop plate just clear of the feed tube bobbin. See fig. 4.6.

Operators Notes

Fig.4.6 Bar Feed Spring

1. Stock carriage tube.
2. Steady bush end cap.
3. Stop plate.
4. Screw.
5. Bush.
6. Latch.
7. Feed tube bobbin & aligning ring, fully back position.
8. Centre stop.
9. Aligning ring.
10. Bar feed strip switch operates when this dimension is 7/16".
11. Collet operating shoe.
12. Drum housing face.
13. Collet operating lever.
14. Adjust nuts to 0.010 clearance when the slide is in the closed position after operation by the cams.
15. Collet operating slide.
16. Roller carrier.
17. Roller bracket.
18. Bar feed slide.
19. Bar feed scale.
20. End bracket.
21. To increase spring pressure turn square head clockwise.
22. Bar feed spring housing.
23. Bar feed spring.
24. Clamp.
25. Bar feed disengage knob.

Fig.4.6 Bar Feed Spring

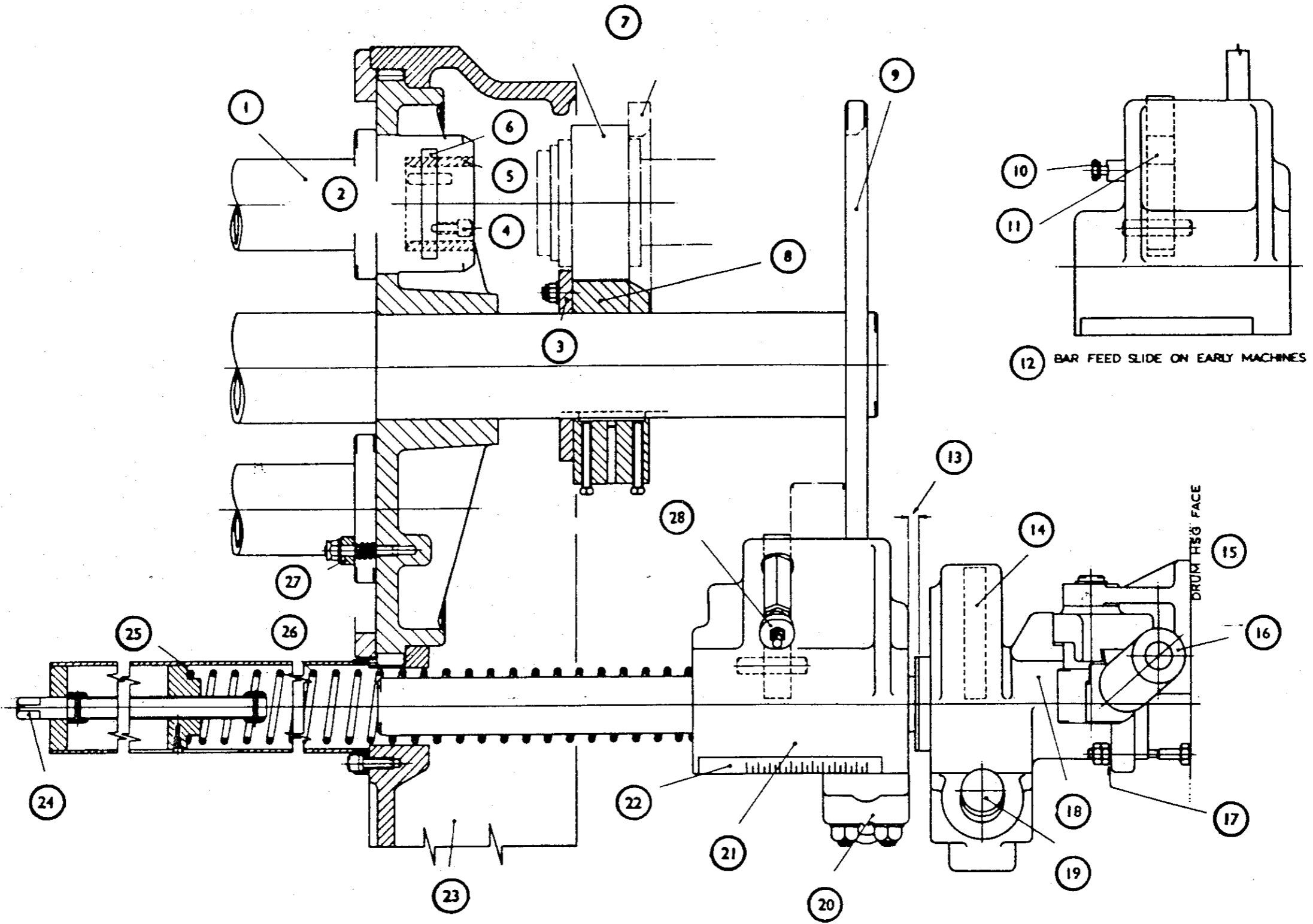

558 Z 10A

4.6 Bar Feed Cams for the 1.3/4"-8, 1.3/4"-8S and 50mm-8 Spindle M/cs

1/2in to 5in(12.7 to 127mm) cam is supplied as standard. 5in to 10in (127 to 254mm) 544Y106B is available to order.

The bar feed cam on the 1.3/4"-8S spindle arranged for spindle stopping.

1/2in to 5in(12.7 to 127mm) cam is supplied as standard. 1.1/4in to 6.1/4in (32 to 159mm) is available to order.

4.7 Adjusting the Bar Stop

Bar feed station 1.

Coarse adjustment is made by transferring a pin locating the bar stop casting along a series of holes in the operating shaft. Fine adjustment is effected by turning a square headed screw on the bar stop casting.

On the machines arranged to bar feed at station 1, the operating mechanism is arranged to swing the bar stop up to the spindle between stations 1 and 2. It can be modified to swing the bar stop over the 1st station cross slide to the bar feed position. This modification is more fully covered in the maintenance handbook.

4.8 Bar Loading

Bar stock should be in good condition, clean, straight and free from scale, corrosion and paint in order to keep the down time for bar loading to a minimum. Dependent on the component geometry and cycle time, bar loading can account for a large proportion of the down time on the machine, hence the quality of the bar is an important element of high operational efficiency. To remove an unsatisfactory bar in a machine loses valuable working time; bars with a large diametral tolerance is also disadvantageous. The grading of bars to the same approximate overall length is recommended.

In order to assist bar loading the bars should be chamfered at each end and the end faces squared to minimise drill breakage.

The machines are fitted with bar exhaustion automatic stop control to stop the machine automatically with the collet open, the machine feed disengaged and the main motor stopped in order to permit the operator to remove the bar end and rebar the machine.

On eight spindle machines, bar exhaustion is signalled not at the end of the cycle but at the start of the cycle for re-barring. It is necessary to remove the bar end manually from the collet before loading a new bar. On short components with the bar stop close to the collet, insert the hand lever into the socket in the stop bracket and swing the stop sufficiently clear to remove the bar end. The bar ends must not be allowed to drop into the swarf conveyor trough.

Enter the new bar into the feeder tube. The machine has a cast step on the bar feed slide, on which a lever can be supported to enable large diameter bars to be easily lifted into position to pass through the feed tube steady bush. Insert a short length of bar into the stock tube and tap the new bar through the feeder and the collet for a suitable distance. This distance depends on the tooling set up and the condition of the end of the bar. Where the bar is fed out, partially machined on the previous cycle, i.e. drill through deeper than the part-off tool datum or broken down behind the part-off tool datum. It is essential that the tools advancing in fast motion clear the new bar. It is wise to feed the new bar a short distance beyond the part-off datum in order that the end of the bar can be prepared during

the first complete cycle. This ensures that none of the tools foul the new bar in fast motion when the new bar is fed to the bar stop and the machining takes place.

After loading a new bar, close the collet with the hand operating lever, adjust collet tension as necessary. Collets should close with a good swift pull on the hand lever, the operator standing sideways to the machine to enable the weight of the body to assist the operation. The horizontal action of the hand lever enables collet tensions greater than normal requirements, to be set using a longer lever. Unless it is absolutely necessary, i.e. extremely heavy combined end cuts on tough alloy steels, extra tension should not be used.

Under no circumstances should a collet tension be set that cannot be easily closed by a lever of four feet (1200mm) maximum length. Do not use the "inch" or "jog" button to close the collet under power.

The spring load for bar feeding is adjustable, this adjustment should be set to the minimum required for consistent bar feeding length. Screwing the square ended shaft on the spring tube clockwise increases the spring load.

4.9 Setting the Longitudinal Slides

The centre tool block and the front and rear independent longitudinal slides are adjusted for feed stroke on the three quadrants shown on fig 4.7. Adjustment is easier with the machine stopped in the "dwell" position at the end of forward feed as indicated on the timing dial and with the stops on the centre block and the independent slides adjusted clear.

Loosen the two hexagon socket screws in the setting block sufficiently to permit the block to be moved to the required stroke, indicated on a scale on the quadrant. Re-tighten the screws and re-set the slide stops.

The linear position of the two independent longitudinal slides can be adjusted 3.1/2in (88.9mm) by the means of the hexagon nuts along a screwed pusher rod, and the slide stops may be moved into several positions to accommodate this adjustment. The centre tool block position is not adjustable and the forward position is approximately constant.

Fig.4.7 Setting Longitudinal Slides

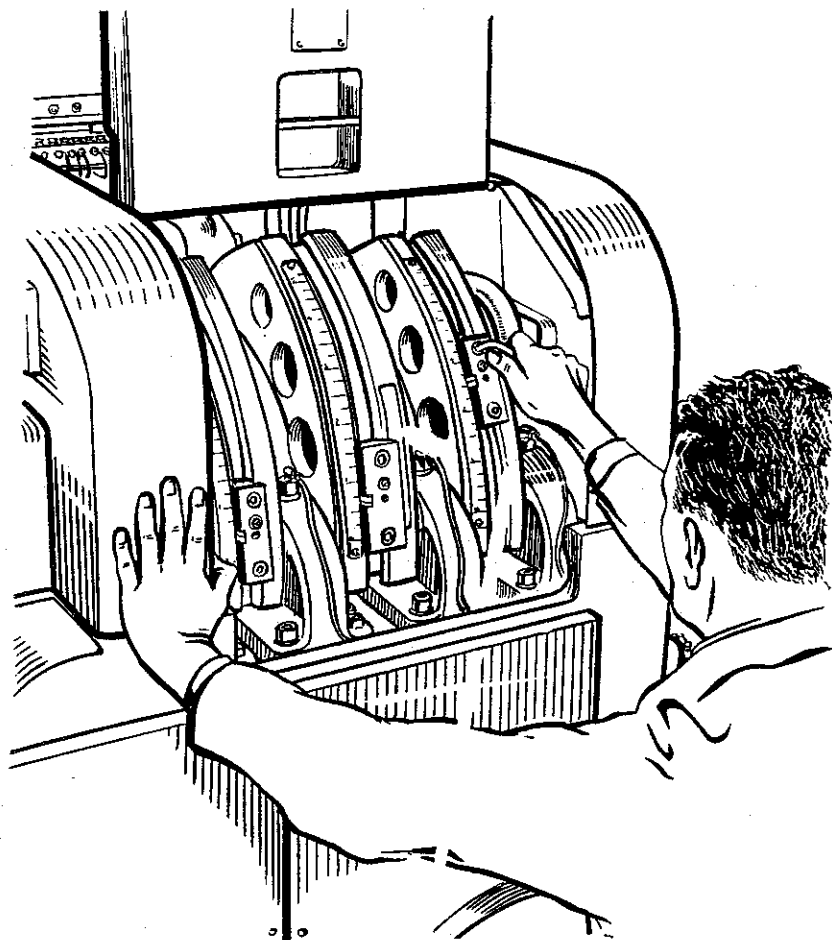

4.10 Cross Slide Adjustment

The capacity charts give the maximum forward and back positions and the main dimensions of the cross slides.

Linear adjustment is made by releasing the clamping nut on the top face of the slide and turning the graduated "micrometer" knob as required. Tighten the nut after adjustment to avoid strain on the adjusting screw.

All cross slides except the cut off slide in station 8 on the 1.3/4"-8, 1.3/4"-8S and the 50mm-8, are fitted with dead stops bearing on stop screws in the spindle drum. At each indexed position of the spindle drum, each slide operates against a different stop screw, so that small errors as may exist in the positions of the spindles within the drum can be cancelled out. The drum stop screws are normally set at Wickman Bennett before despatch, but if small consistent errors are obtained during running, the screws can be adjusted with the spanner supplied.

The cross slide mounted dead stops should be re-set after each slide and each stroke adjustment.

4.11 Cross Slide Stroke Adjustment

The lower hinged doors on the drum housing at the front and rear of the machine provide access to the stroke adjustment mechanism for all the cross slides.

A special ring spanner is supplied to release the hexagon nuts on the pivots at the lower ends of the operating links. Adjustment is made by sliding a pivot along the rocking lever tee slot and re-tightening the hexagon nut. Scales on the rocking lever and an indicator on each pivot block show the feed stroke set.

The setting should be made with the machine stopped at the "dwell" position at the end of the forward feed stroke and the cross slide adjusted clear of the dead stop. This is particularly important when re-setting intermediate cross slide feed strokes (3rd and 4th, and 7th and 8th stations).

The upper cross slides may be set from the "standard" range of strokes to a "long" range of strokes, the long range of strokes on the upper cross slides being twice the scale reading. The change over is obtained by removing the covers on the top of the drum housing and transferring the upper link pivot connections from the outer hole "B" in the operating lever to an inner hole "A". Machines are normally supplied with the link pivot connection fitted to the outer hole "B". Instructions for this operation are to be found in the 'Maintenance Manual'. See fig. 4.8.

4.13 Other Adjustments

Other adjustments, including auxiliary cross slide and auxiliary longitudinal motions are described in the section on attachment adjustment. Details are also described in the 'Maintenance Manual' supplied with this machine.

Fig.4.8 Cross Slide Stroke Adjustment

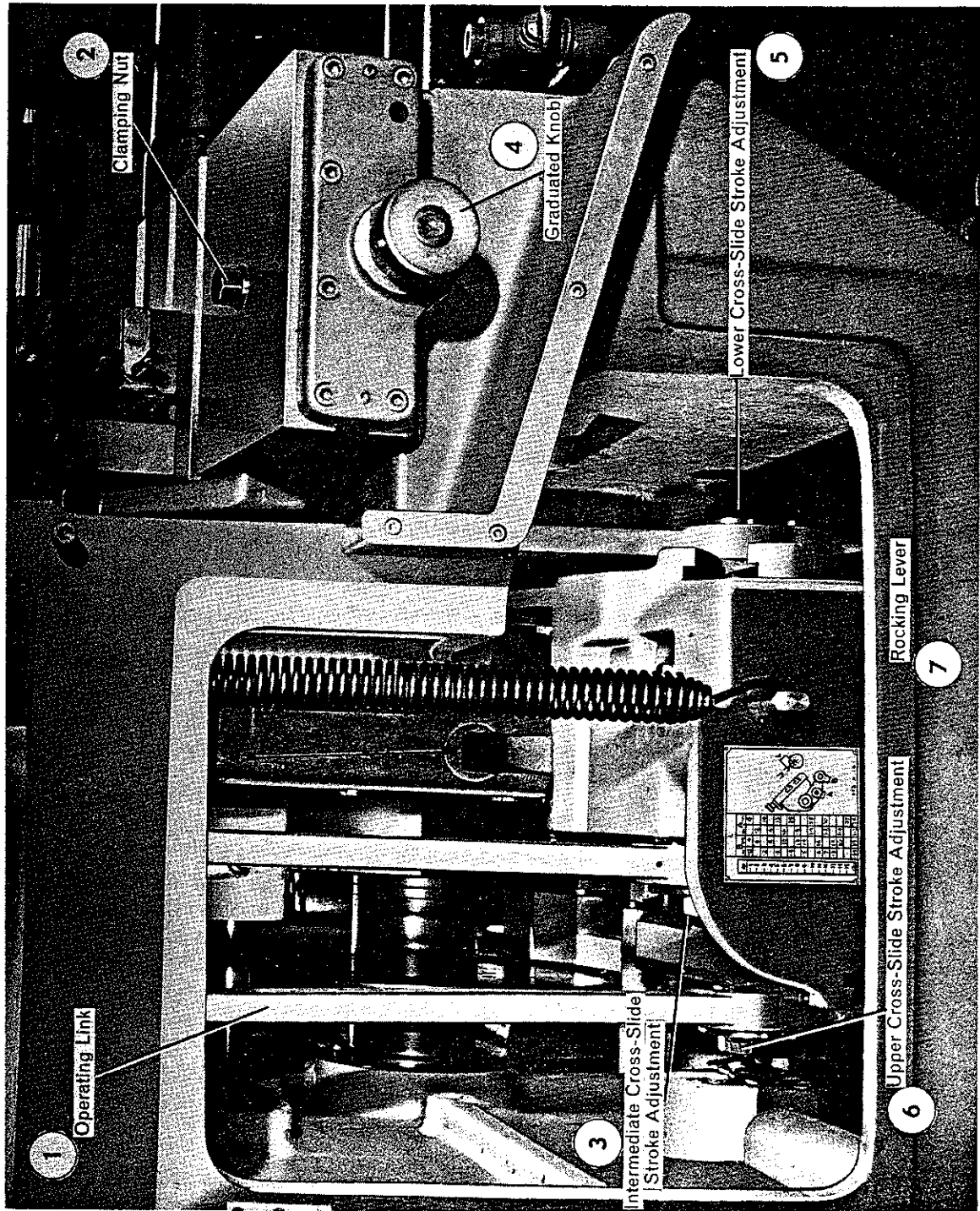

Operators notes

SECTION FIVE - ATTACHMENTS

5.1 High Speed Drilling (Section 590K for 1.3/4"-8S - Section 590L for the 1.3/4"-8 and 50mm-8 machines)

This attachment can be fitted in all stations singly or in combination (see section charts, section 5.14).

The head unit can be mounted in a bracket clamped to the centre block or either of the two longitudinal slides or mounted in the reaming body and slide unit in 3rd, 4th, 7th or 8th stations. The driving gear is fitted into the machine as standard. All idler gears should be fitted so that the bracket "trails" and so, in case of a jam, will tend to throw the idler out of mesh.

The "ratio" gives the relative speed of drill and work. A ratio of 2:1 means that the relative drill speed is twice the work spindle speed, ie., the "ratio" quoted allows for the fact that the drill and work spindle rotate in opposite directions. The attachment accommodates parallel shank drills up to 9/16in dia (14.3mm) held in collets.

Locknuts on the drilling spindle control a stop rod providing a fine adjustment for the forward position of the drill and positive end support. See fig. 5.1.

Fig.5.1 High Speed Drilling Attachment

1. Minimum distance to spindle nose 2". Maximum 19".
2. Bracket tool holder } For stns. 3,4,7 & 8
W6-214-20. 5th & 6th } Use body & slide. sec.388
stations }
3. Driving gears are supplied fitted to the machine.
4. A ratio of 2:1 means that the relative speed of a drill to work is twice the work spindle speed.
5. Driving gear.
6. 1.3/4"-8 available ratio (not on Spindle Stopper m/c)
7. Idler.
8. Driven gear.
9. Ration.
10. Driving gear.
11. 6"-8 available ratio (including 1.3/4"-8S and 50mm-8 m/c's).
12. Idler.
13. Driven gear.
14. Ratio.
15. High speed drilling drive
Sec. 590L - 1.3/4"-8
Sec. 590K - 1.3/4"-8S & 50mm-8.
16. Fitted driving gear.
17. Idler.
18. Driven gear.
19. View of locator peg for stns. 3, 6 & 7.
20. Attachment face.
21. Adjust to give .005 backlash between idler & driving gear.
22. View in direction of arrow 1.3/4"-8 only.
23. 5th station.
24. 6th station.
25. 5th station.
26. 6th station.
27. View in direction of arrow 1.3/4"-8S & 50mm-8.
28. Live spindle unit Sec.13 group 'K'.
29. 1.9/16" dia. maximum capacity.
30. Collet S248A.
31. Locknuts for drill stop.

Fig.5.1 High Speed Drilling Attachment

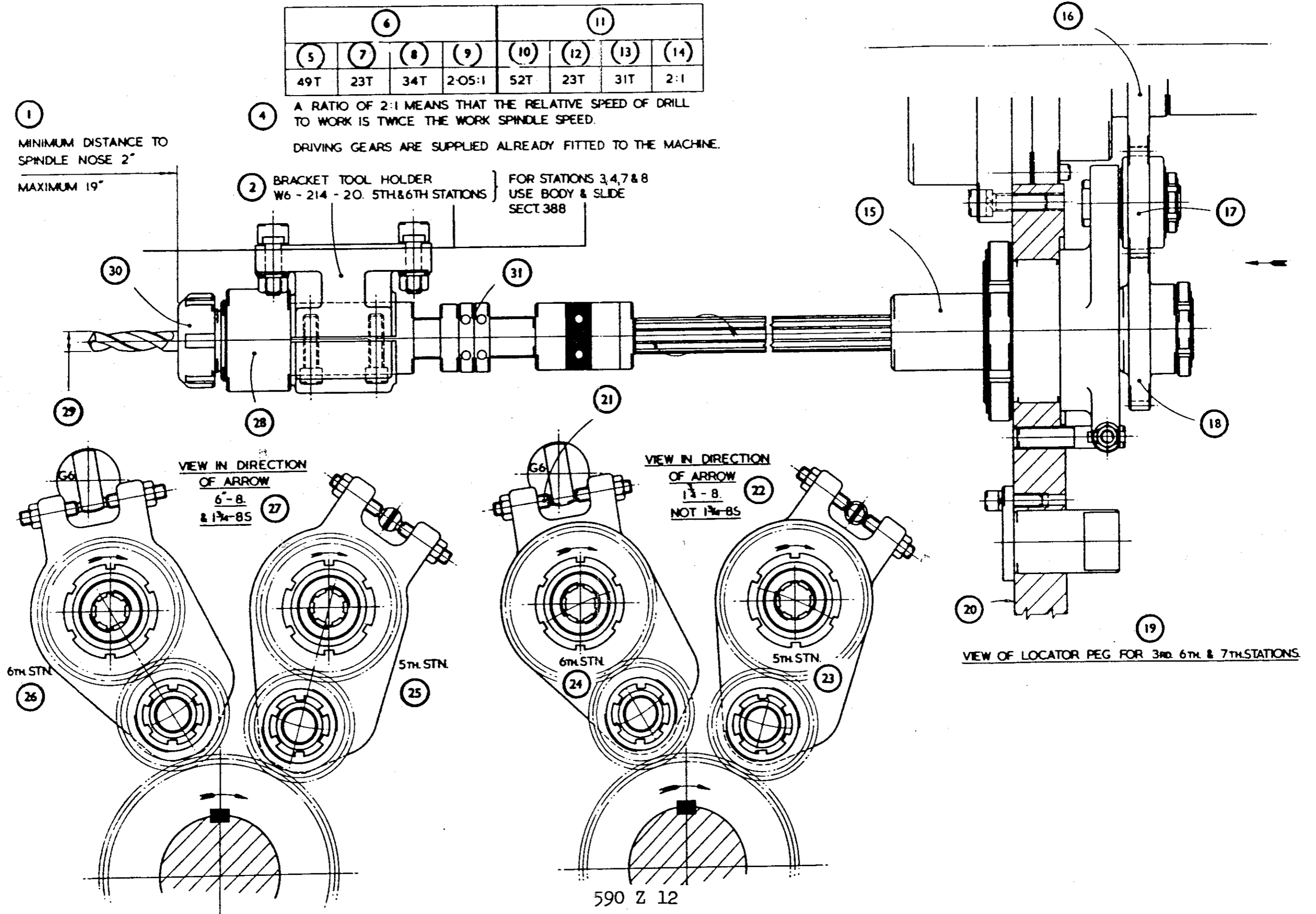

5.2 Auxiliary Longitudinal Motion (Section 599A, 3rd, 4th, 7th or 8th Stations. Section 599B, 8th Station only)

The auxiliary longitudinal motion is used for pushing threading attachments or independent reaming attachments in the 3rd, 4th, 7th and 8th stations. See fig. 5.2.

The pivot bracket has three holes for the fulcrum pin and two positions on the face of the main drive housing, offering a total of six fulcrum positions.

The link connection to the attachment is in a graduated slot providing fine adjustment of stroke. The ranges covered by this graduated slot for each fulcrum position overlap. A choice of fulcrum position is thus available and may be used to avoid moving the bracket or fulcrum pin.

A shear pin is provided in the upper link. In the event of a jam, the shear pin will be broken and the forward feed disconnected but the attachment will be positively withdrawn from the work. In the 3rd station this shear pin may be replaced by a solid bolt if desirable, owing to the potential danger to subsequent tooling should the 3rd station attachment fail to function.

The attachment, section 599A, is interchangeable between the 3rd, 4th 7th and 8th stations, although some re-assembling is necessary. If longitudinal motion is required in both 7th and 8th stations, the section 599A is used in station 7, and section 599B in station 8. Section 599A uses extra cams mounted upon the upper camshaft disc. Section 599B uses extra cams mounted upon the auxiliary cam drum on the main camshaft. See section charts, pages 98 and 99.

When using section 599A for pushing in stations 3 or 8, the threading bracket 597.E Mk 1, is turned through 180 degrees from the position shown on fig. 5.3.

Fig.5.2 Auxiliary Longitudinal Motion

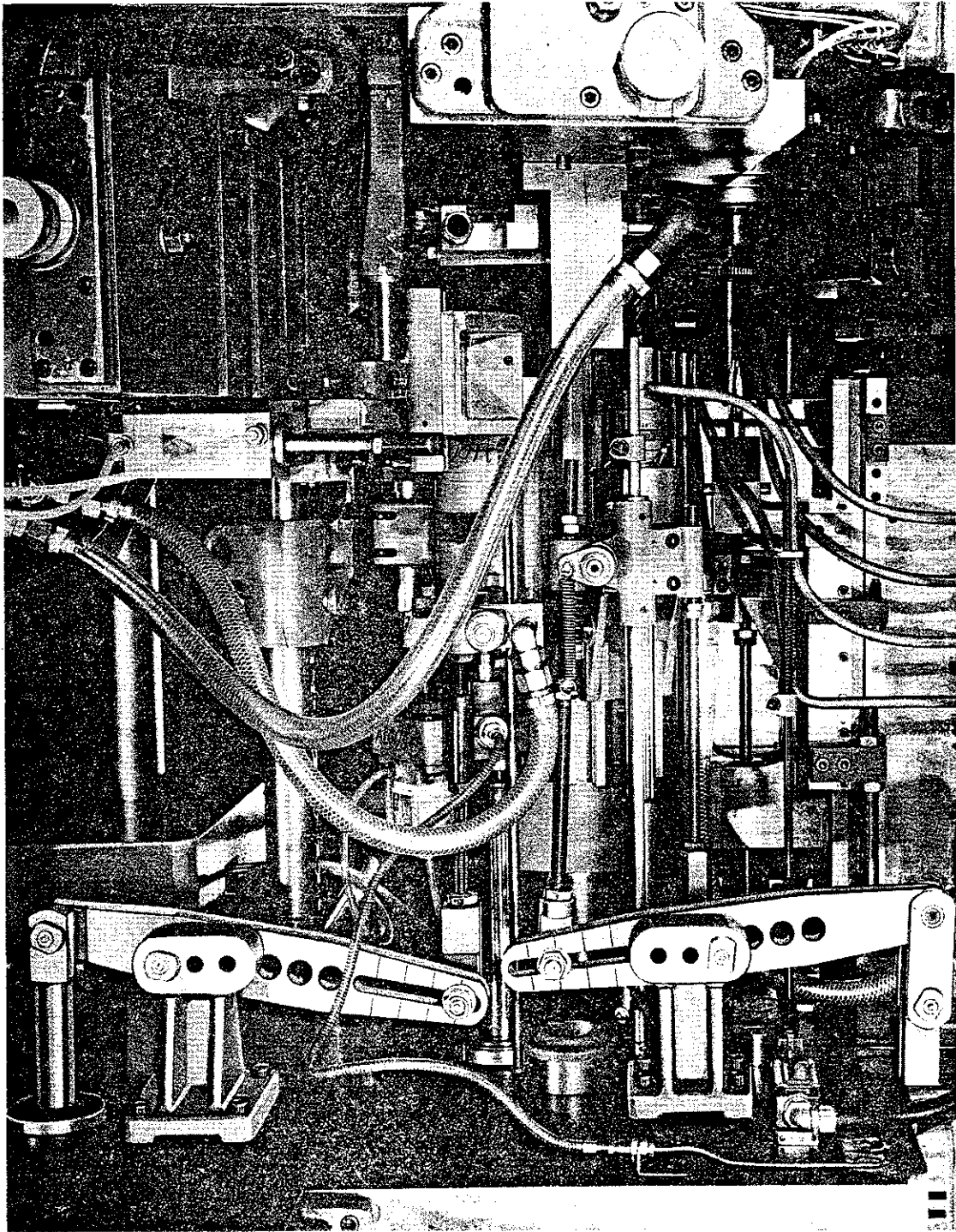
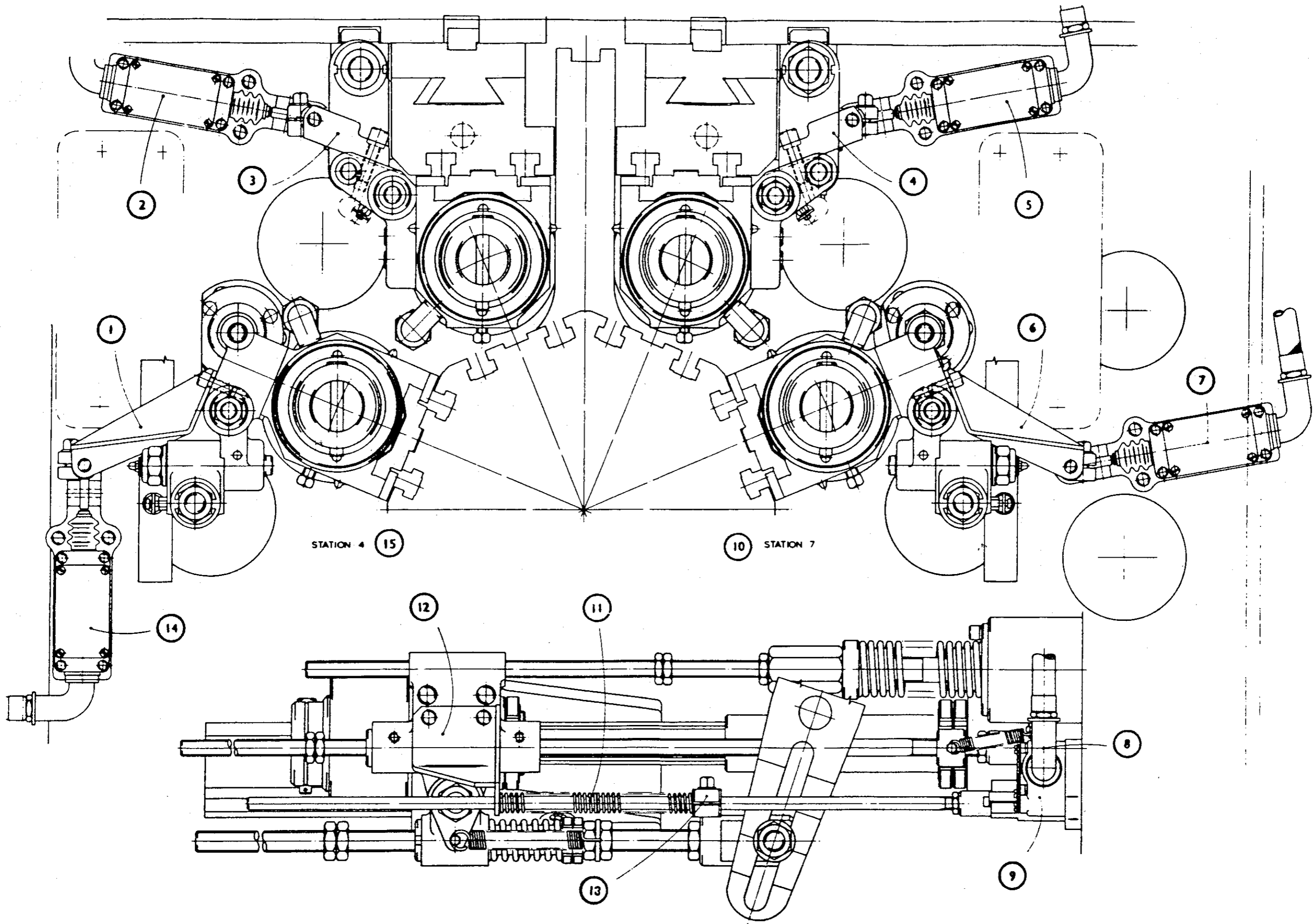

Fig.5.3 Micro Switches for checking Threading Attachment Return

1. Stop plate.
2. Sec. 597 H/5.
3. Stop plate.
4. Stop plate.
5. Sec. 597 H/6.
6. Stop plate.
7. Sec. 597 H/7.
8. Sec. 597 H
9. Sec. 186F.
10. Station 7.
11. Spring.
12. Stop plate.
13. Set clamp to operate micro switch just before cam timing switch closes and with attachment clear of work piece.
14. Sec. 597 H/4.
15. Station 4.

Fig.5.3 Micro Switches for Checking Threading Attachment Return



597 Z 13

5.3 Jackshafts (Sections 597C)

Jackshafts are used mainly to drive threading attachments. They run at spindle speed but in the opposing direction, being driven by chain from the centre shaft. See fig. 5.4.

Should attachments fitted in the attachment bores be required to run at spindle speed, a 1:1 gearing will give this from the jackshaft. Standard 38-tooth gears 8 D.P. give this ratio. See Synchronous Drive section.

When the jackshaft is used to drive the clutch threading drive, one "Off" ratio and one "On" ratio is provided from each jackshaft. Where two clutch threading drives are driven from one jackshaft, the "Off" ratio must be the same for both attachments, and both attachments must be cutting the same hand of thread.

Fig.5.4 Jackshaft Arrangement Sec. 597 C Mk1

1. Jackshaft
2. Jackshaft sprocket
19T 1.3/4"-8
15T 1.3/4"-8S & 50mm-8
3. 1.3/4"-8
68 pitches of Reynold Duplex chain Ref. 114046
1/2" Pitch - .335" Roller

1.3/4"-8S & 50mm-8
68 pitches of Reynold Duplex chain Ref. 114038
1/2" Pitch - .335" Roller
4. Jockey sprocket 19T
5. Drive sprocket 26T
6. Centre shaft.

Fig.5.4 Jackshaft Arrangement Sec.597C Mk1

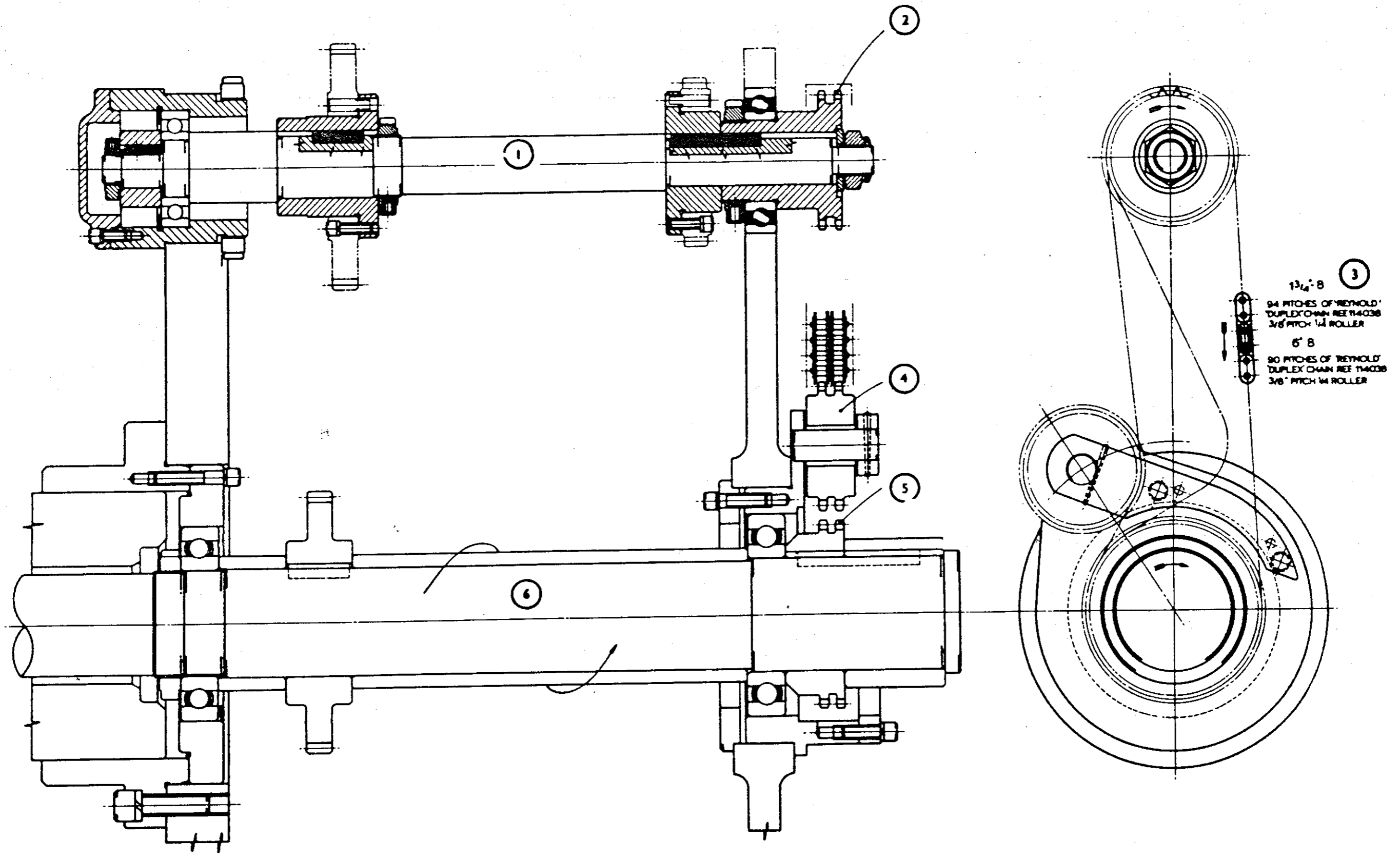

500 Z 214

5.4 Slow Speed Reaming

In some circumstances it is desirable to ream at a lower surface speed than is possible with the existing spindle speed which may have been fixed by other tooling. If the reamer is driven in the same direction as the work spindle but at a faster or slower speed, the difference between the speed of the work and that of the reamer will provide a suitable speed for reaming.

This rotation of the reamer can be obtained by mounting the reamer holder in a threading spindle, Section 586, and using other related sections as for a revolving diehead.

Right hand reamers should be driven slower than the spindle speed and left hand reamers faster than the spindle speed.

The effective reamer R.P.M. = $\frac{\text{Work_Spindle_R.P.M.}}{\text{Ratio}}$

See fig. 5.5.

Fig.5.5 Slow Speed Reaming

① RIGHT HAND REAMERS.

② DRIVER	31	32	33	34
③ DRIVEN	46	45	44	43
④ RATIO	3.07	3.46	4.0	4.78

* * * *

⑤ LEFT HAND REAMERS

⑥ DRIVER	46	45	44	43	42
⑦ DRIVEN	31	32	33	34	35
⑧ RATIO	2.07	2.46	3.0	3.78	5.0

* * * *

⑨ * GEARS NORMALLY IN STOCK.

5.5 Independent Reaming (Sections 599A and 599B)

This attachment is available for use in stations 3, 4, 7 or 8. It is operated by the auxiliary longitudinal motion (Section 599A), or by section 599B (station 8 only)

Although particularly designed for reaming operations, the attachment can be used for other end working tools of the shank type and will also accommodate the high speed drill spindle assembly. The slide is attached to the centre tool block. It should be set with a minimum of overhang between the attachment and centre tool block in all positions.

The reaming cams used and the strokes obtained are shown on fig. 5.6. Standard timing cams are timed with the centre tool block while the accelerated timing cams are timed to return early in order to clear the work before parting-off. See fig. 5.7.

Fig.5.6 Independent Reaming Cams & Strokes

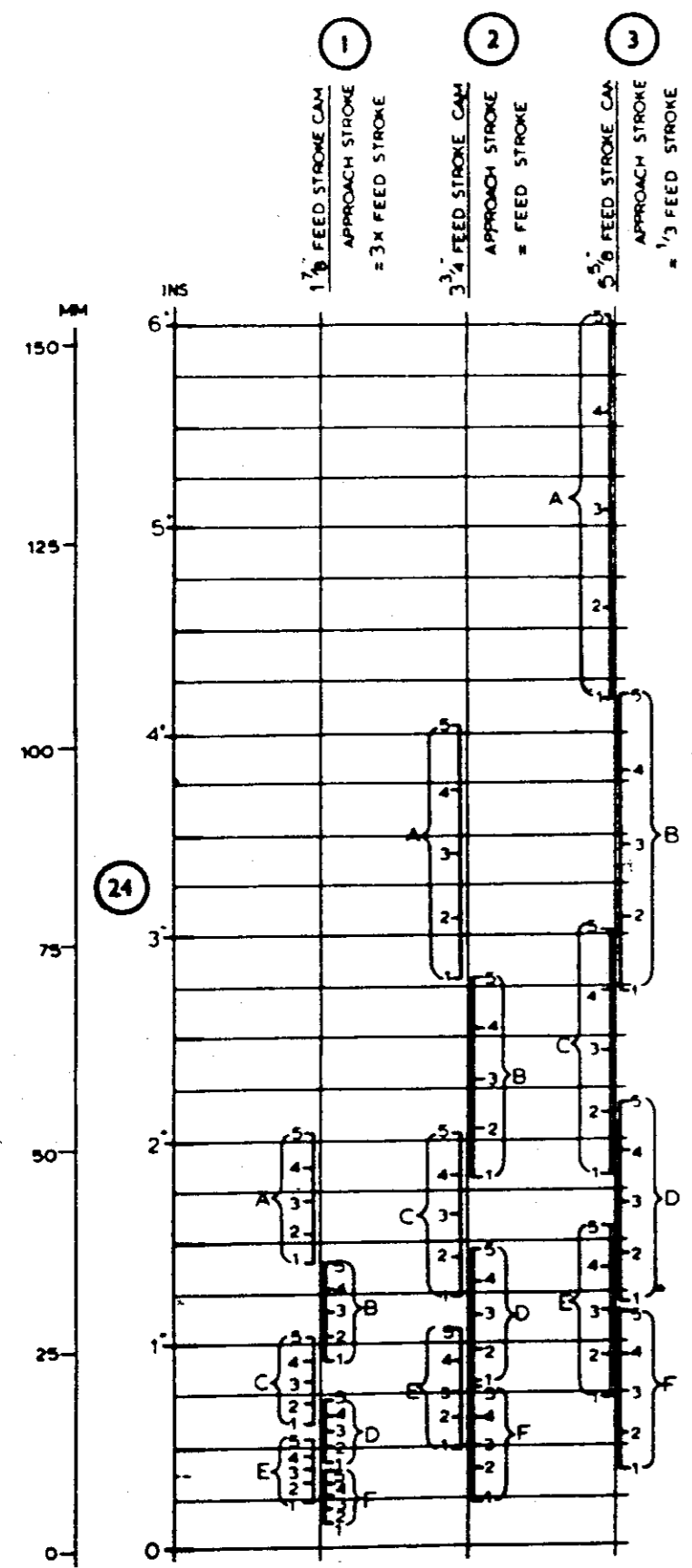

TO READ CHART

- ON FEED STROKE SCALE ON LEFT, MARK THE FEED STROKE REQUIRED.
- DRAW A HORIZONTAL LINE ACROSS TO VERTICAL LINE REPRESENTING CAM FITTED (1 7/8 3 3/4 or 5 5/8 STROKE.)
- WHERE THE HORIZONTAL LINE CUTS THE BRACKETS ON THE VERTICAL LINE GIVES THE PIVOT POSITION (A B ETC) AND THE RELATIVE POSITION OF THE PUSHER CONNECTION AND THE GRADUATIONS ON THE LOWER END OF THE LEVER (1 2 ETC)

REAMING

TO OBTAIN FEED PER REV

STANDARD TIMING CAMS (STATIONS 3 & 4 ONLY) - FEED PER REV IS THE SAME AS SHOWN ON THE SPEED AND FEED CHART FOR THE PARTICULAR STROKE IN USE

ACCELERATED TIMING CAMS (STATIONS 3 & 4, 7 & 8) - MULTIPLY ACTUAL STROKE BY TWO AND FIND FEED PER REV FOR THIS STROKE FROM SPEED AND FEED CHART

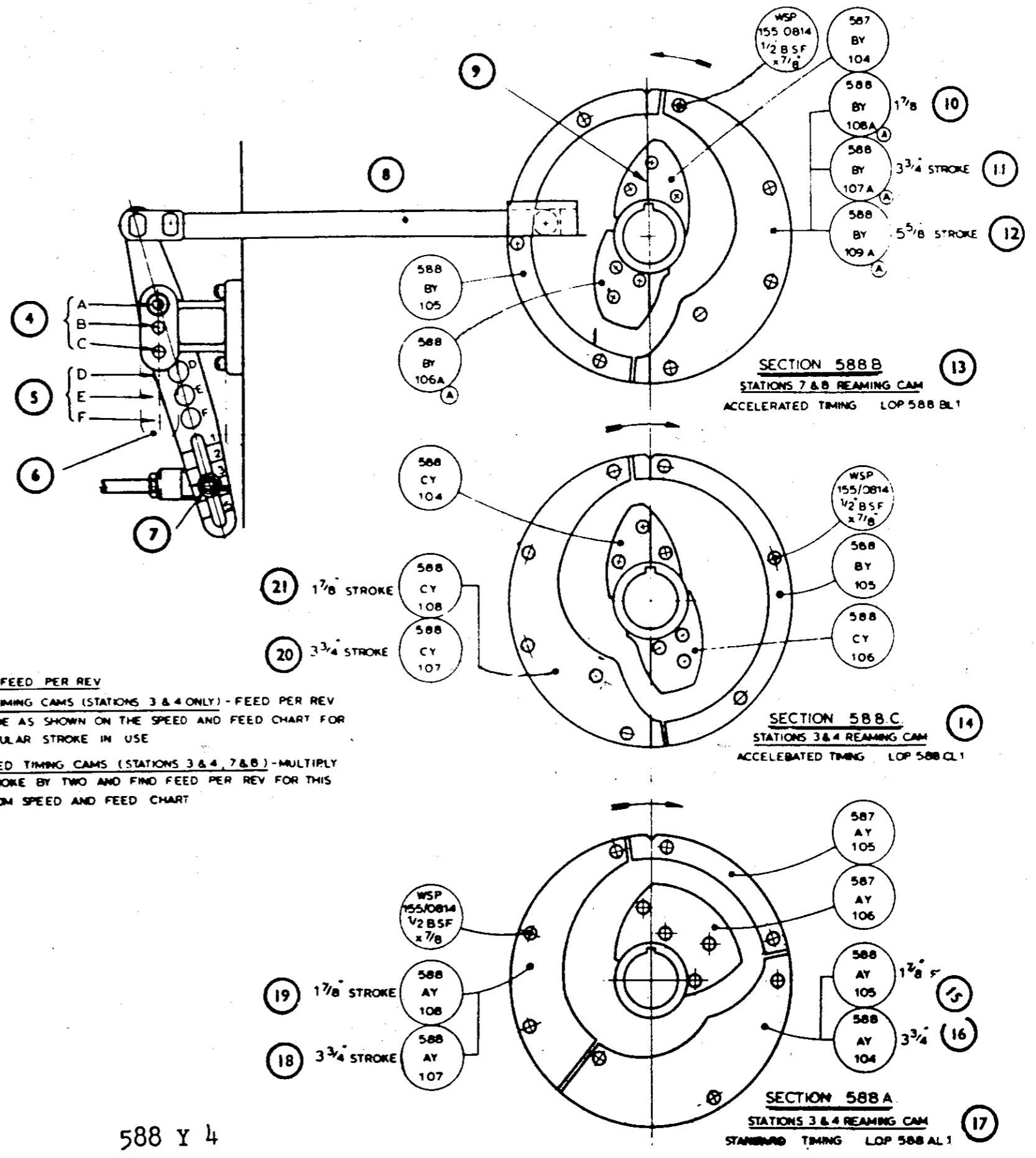

588 Y 4

Fig.5.7 Reaming Attachment Stations 3,4,7 & 8

1. Station 7.
2. Reaming bracket Sec. 598 C
3. Clamp Sec. 388 Mk1.
4. Stop rod Sec. 388 Mk1.
5. Body & slide Sec. 388 Mk1.
6. Sec 388 Mk1.
7. Upper pusher arm Sec. 599 A
8. Sec. 598 C
9. Sec. 598 D
10. Lower pusher arm Sec. 599 B
11. Body & slide Sec. 388 Mk1.
12. Nuts Sec. 599 B
13. Push rod Sec. 599 B
14. Reaming bracket Sec. 598 D
15. Station 8.
16. Push rod Sec. 599 A

Fig.5.7 Reaming Attachment Stations 3, 4, 7 & 8

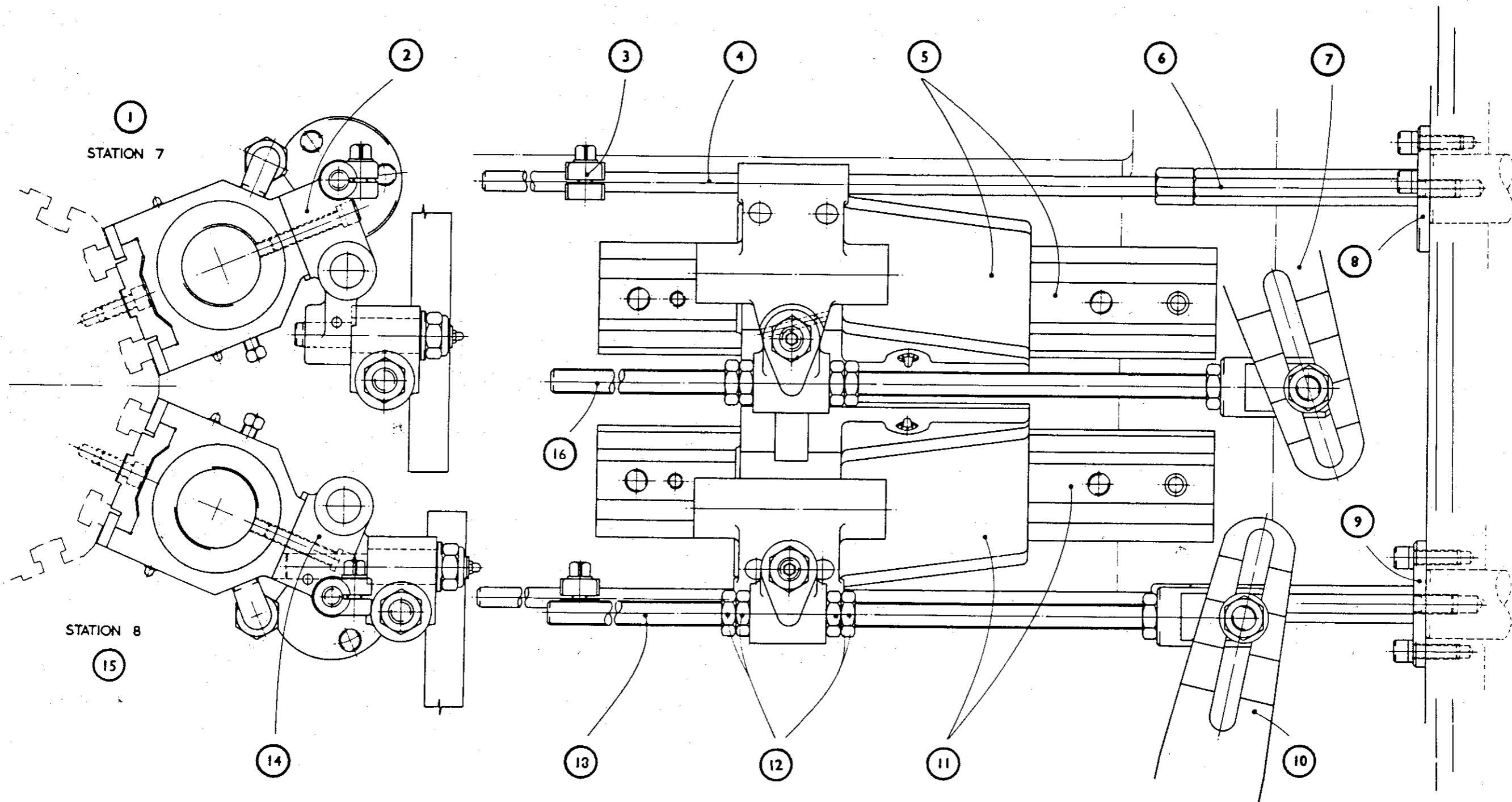

598 Z 10

5.6 Threading Attachments

Threading can be performed in stations 3,4,5,7 and 8. Fig 24 show the sections required to use combinations of diehead drives and threading clutch drives in various stations.

There are two basic attachments; one for use in stations 5 and 6, the other is used in stations 3, 4, 7 and 8.

Drives

Threading operations are usually performed at lower surface speed than those suitable for turning or drilling and as it is not possible to vary the spindle speed during the cycle, and in order to obtain suitable surface speeds for threading whilst still using economical work spindle speeds, it becomes necessary to rotate the threading tool in the same direction as the work spindle but at a faster or slower speed. The difference between the work spindle speed and the threading tool speed will then provide an effective surface speed for threading.

A commonly used threading speed is one-fifth of the work spindle speed, requiring the threading tool to be rotated at four-fifths of the work spindle speed for right hand threads, or one-and-one-fifth times the work spindle speed for left hand threads. This is termed an "On" ratio of 5, being the ratio of work spindle revolutions to threading revolutions during the "On" threading of the die or tap. If the cycle time permits, slower ratios may be used to reduce cutting speeds, increase tool life and improve finish. Faster ratios may be employed on free cutting materials, thus permitting faster machine cycle times.

For example, with a work spindle speed of 500 r.p.m. and threading ratio of 5

$$\text{the effective threading speed} = \frac{500}{5} = 100 \text{ r.p.m.}$$

a "faster" ratio would be 4

$$\text{effective threading speed} = \frac{500}{4} = 125 \text{ r.p.m.}$$

For right hand threads and a ratio of 5, gears would be required to rotate the threading spindle at $500 - 100 = 400$ r.p.m. (Left hand threads $500 + 100 = 600$ r.p.m.)

Since a solid tap or die after cutting the thread must also be run "Off" the component during the feed cycle, it is desirable that this non-productive operation be performed as quickly as possible. Excessive difference between forward and return speeds will, however, cause increased clutch wear and a possible difficulty in maintaining threaded length. These return speeds are termed the "Off" ratio and an "Off" ratio of 2 is normally used.

When using self-opening dieheads, the diehead drive (Section 597A) is used to drive the attachment. The diehead drive is driven from a jackshaft. This gives an "On" ratio only. See fig. 5.8.

Operators Notes

Fig.5.8 Threading Drive

1. Spring box G6.
2. Position 6.
3. Jackshaft J6.7.
4. Position 7.
5. Spring box G7.
6. Sec. 597 A.
7. Threading drive with clutch drive. See 597 BZ 1.
8. Jackshaft. See 5978 Z1.
9. Threading drive for diehead attachment
10. Right hand On.
11. Jackshaft and spindles always run at the same speed, but in opposite directions.
12. Centreshaft.
13. Threading shaft (A).
14. Jackshaft (B).
15. Spindle.
16. Threading ratio =
$$\frac{1}{1 - \frac{\text{Gear on 'B'}}{\text{Gear on 'A'}}}$$
17. Ratio Spindle = 1
Jackshaft
18. Threading ratio.
19. Threading shaft.
20. Jackshaft.
21. Left hand ON.
22. Available threading gears and threading ratios.
23. Spindle position 1.
24. 'G8' diehead anchor plate.
25. Jackshaft 'J7 8'.
26. Position 8.
27. Centre drive shaft.
28. Machine.
29. Indexing.

When using solid taps/dies the clutch threading drive (Section 597B) is used together with section 597A, this is also driven from a jackshaft. This attachment gives an "On" ratio and an "Off" ratio. By permanently engaging the "On" side of the clutch, this drive may be used with self-opening dieheads, see fig. 5.9.

When considering the use of a threading attachment it is first necessary to establish the number of work spindle revolutions required. These depend on the lead, the length of thread and threading ratios used; an allowance of two threads is usually made for starting.

Fig.5.8 Threading Drive

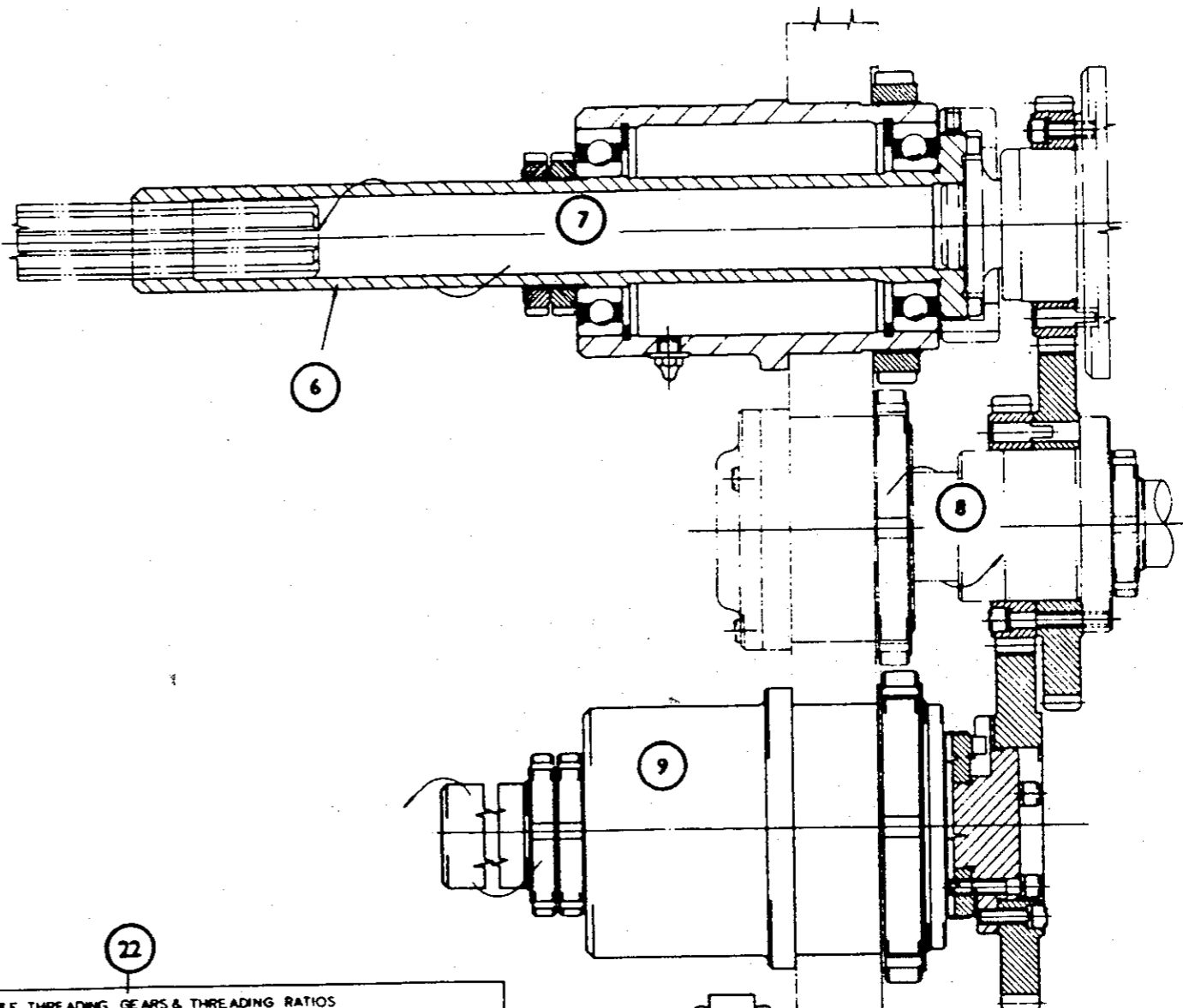
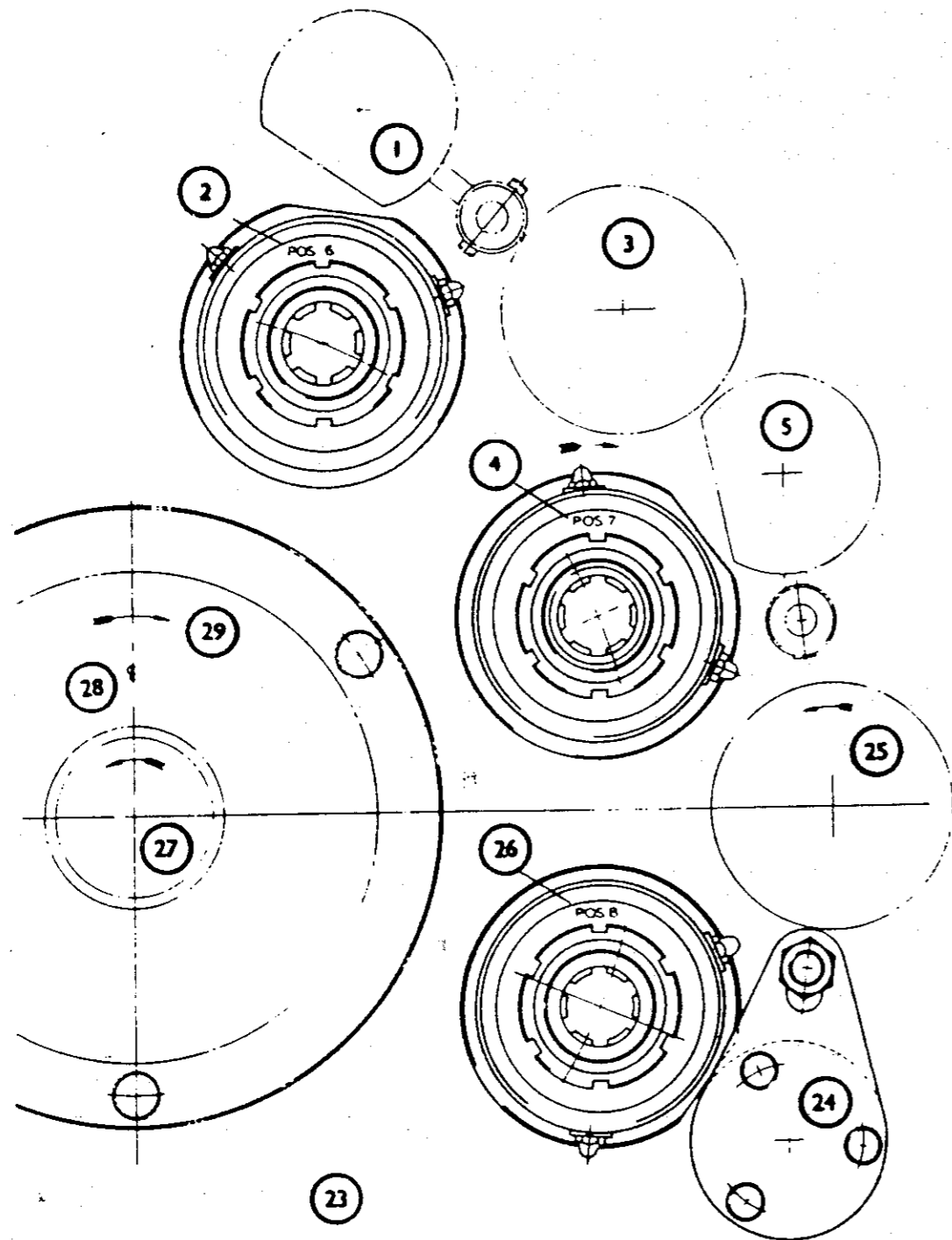

21

		AVAILABLE THREADING GEARS & THREADING RATIOS															
		LEFT HAND ON							RIGHT HAND ON								
JACKSHAFT		46	45	44	43	42	41	40	39	38	37	36	35	34	33	32	31
THREADING SHAFT		31	32	33	34	35	36	37	38	39	40	41	42	43	44	45	46
THREADING RATIO		2.072	4.6	30	378	50	7.2	12.33	37.99	39	33	8.2	6.0	4.78	4.0	346	3.07

20

19

18

17

16

15

14

13

12

11

10

JACKSHAFT & SPINDLES ALWAYS RUN AT THE SAME SPEED BUT IN OPPOSITE DIRECTIONS.

RATIO SPINDLE/JACKSHAFT = 1

CENTRESHAFT

THREADING SHAFT (A)

SPINDLE

JACKSHAFT (B)

THREADING RATIO = (GEAR ON B / GEAR ON A)

500 Z 34

Fig.5.9 Threading Clutch

1. See 597 AZ 1 for arrangement of diehead drive.
2. 'OFF'.
3. Jackshaft.
4. 'ON'.
5. Left hand 'ON' - Right hand 'OFF'.
6. Available threading gears and ratios.
7. Right hand 'ON' - Left hand 'OFF'.
8. Jackshaft.
9. Threading shaft.
10. Threading ratio.
11. Jackshaft (B) and spindles always run at the same speed but in opposite directions.
12. Ratio: Spindle = 1
 Jackshaft
13. Centreshaft.
14. Threading shaft 'A'.
15. Jackshaft 'B'.
16. 'Screw On' gears.
17. 'Screw Off' gears.
18. Spindle.
19. Threading ratio - 1
 Gear on 'B'
 1 - Gear on 'A'
20. Drawing Ref. No.
21. Available gears.
22. No. of teeth.
23. Assembly of glut shaft showing locking arrangement & diehead trip rod.
24. Spindle station 8.
25. Jackshaft J78.
26. Indexing.
27. Spindle drum.
28. Spindle station 7.

Fig.5.9 Threading Clutch

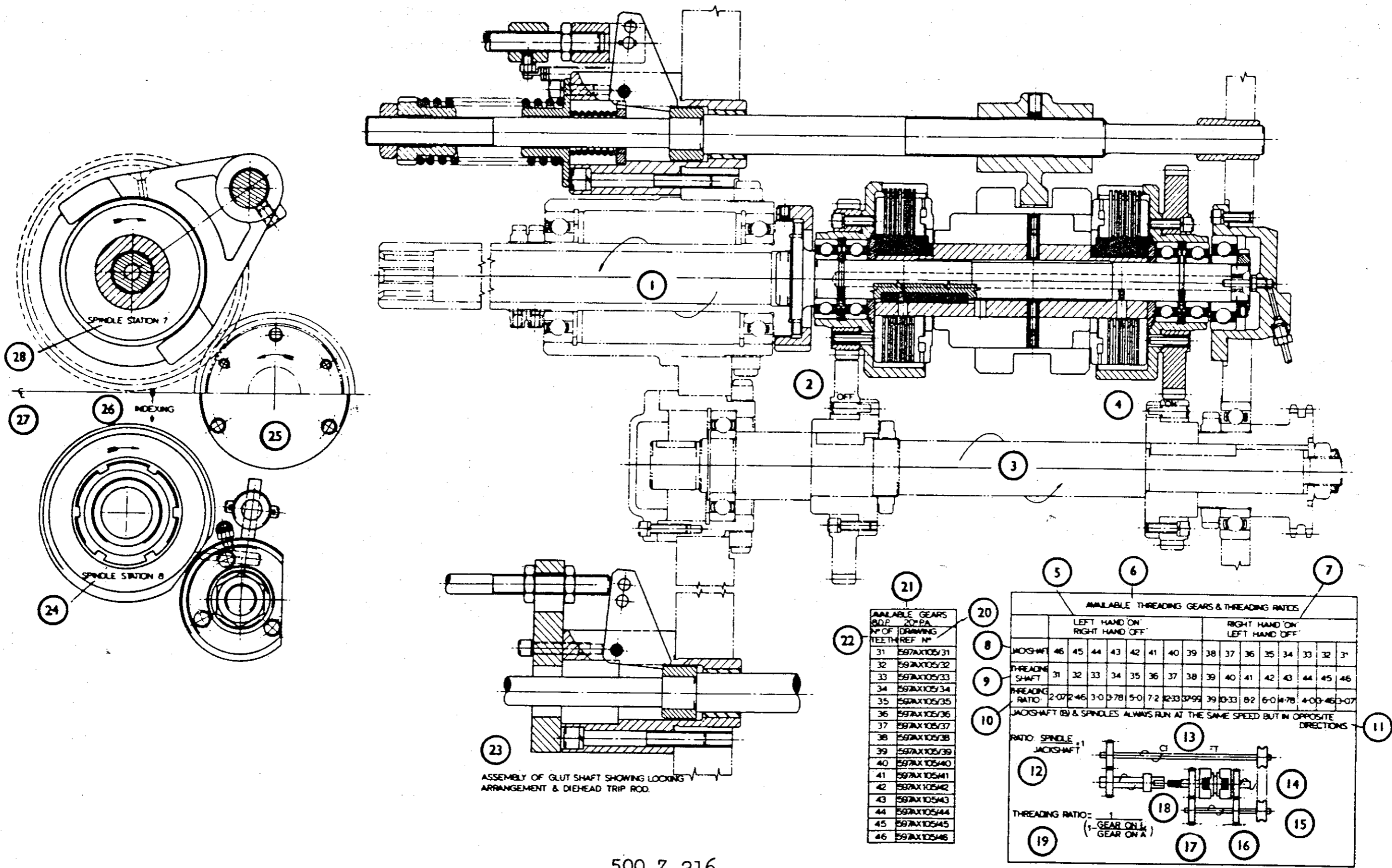

500 Z 216

Self-Opening Dieheads

When using self-opening dieheads the number of work spindle revolutions required may be found by multiplying the number of threads to be cut, plus the allowance for starting, by the "On" ratio used.

For example, to cut a 20 t.p.i. thread 3/4" long with an "On" ratio of 5:

$$\begin{aligned} \text{Number of threads to be cut} &= 3/4 \times 20 = 15 \\ \text{Allowance} &= 2 \\ \text{Total} &= 17 \end{aligned}$$

Work spindle revolutions required with threading ratio of 5
= 5 x 17 = 85 revolutions; OR

For a 1.5mm THREAD x 30 mm long:-

$$\begin{aligned} \text{No. of Threads to be cut} &= 30 / 1.5 + 2 = 22 \end{aligned}$$

Work spindle revs required = 22 x 5 = 110 Revs.

Solid Taps and Dies

When using solid taps and dies extra revolutions must be allowed for the tap or die to run off the job.

For the previous example it was found that the total threads to be cut = 17 and using an "On" ratio of 5 and an "Off" ratio of 2, the total "On" "Off" ratio = 5 + 2 = 7 and the revolutions required = 17 x 7 = 119.

To summarise:

Calculation (a)

Work spindle revolutions for self-opening dieheads = (Length of thread x t.p.i.) + 2) x "On" ratio; OR
(Length of thread ./ Pitch) + 2) x "On" ratio.

Calculation (b)

Work spindle revolutions for solid taps and dies = (Length of thread x t.p.i.) + 2) x ("On" ratio + "Off" ratio); OR
(Length of thread ./ Pitch) x ("On" ratio + "Off" ratio).

The speed and feed charts, pages 17 to 19, show the available work spindle revolutions during the 147 degs. of cutting time in the vertical column n (147 degs.)

When threading in stations 3,4,5 or 6, and using standard timing cams, ascertain that the work spindle revolutions required for threading do not exceed the available cutting revolutions which are given on the speed and feed chart. The available cutting revolutions depend on the cycle time and are determined by the longest operation which, in some cases, may be the threading operation.

When threading in stations 3,4,7 and 8 and employing accelerated timing cams, the work spindle revolutions required for threading should not normally exceed half of the available cutting revolutions. Provision is made for the return cam to be retarded in two 10 degs. steps, giving a maximum 9/16 or 5/8 of the available cutting revolutions for threading.

If the calculated revolutions required for threading exceed the maximum, either the cycle time must be increased to give more available cutting revolutions or faster "On" ratio must be used.

Threading Cams

Threading cams are used with self-opening dieheads or with solid taps and dies. The timing of the movements given by these cams is shown on the timing diagram, fig. 5.10, and the following sequence of movements to the threading push rod is produced.

1. Fast approach stroke.
2. Feed Stroke.
This is set to suit the thread being cut.
3. Drop Back.
This is equal to the amount of the feed stroke and takes place while the threading tool continues, pulling itself along on the thread it is cutting.
4. Dwell.
This continues while the threading tool completes the cutting and, in the case of solid taps and dies, runs off the work.
5. Fast Return.
With accelerated timing cams this occurs while the centre tool block and the cross slides are still feeding forward.

Fig.5.10 Timing Diagram

1. Movement
2. Drum Indexing.
3. Drum locking.
4. Cross slide idle.
5. Cross slide feed.
6. Longitudinal slides idle.
7. Longitudinal slides feed.
8. Not applicable.
9. Lockbolt.
10. Bar stop.
11. Collet.
12. Bar feed.
13. Motion.
14. Threading Stns. 5 & 6.
15. Threading Stns. 7 & 8.
16. Threading Stns. 3 & 4.
17. Reaming Stns. 3 & 4.
18. Reaming Stns. 7 & 8.
19. Timing angle.
20. Indexing.
21. Unlocked.
22. Withdrawn.
23. Withdrawn.
24. Approach.
25. Unlocked.
26. Advanced.
27. Start opening.
28. Open.
29. Dwell.
30. Bar feed.
31. Fast.
32. 205 deg. fast motion.
33. Approach.
34. Approach.
35. Accelerated timing.
36. Approach.
37. Approach.
38. Locked.
39. Advanced.
40. Feed.
41. Advanced.
42. Cam.
43. Feed.
44. Feed.
45. Feed return.
46. Locked.
47. Withdrawn.
48. Fully closed.
49. Closed.
50. Dwell.
51. 155 deg. feed.
52. Slow.
53. Feed
54. Feed
55. Feed.
56. Standard time.
57. Feed.
58. Dwell.
59. Dwell.
60. Dwell.
61. Cam.
62. Cam.
63. Alternative positive returns.

Fig.5.10 Timing Diagram

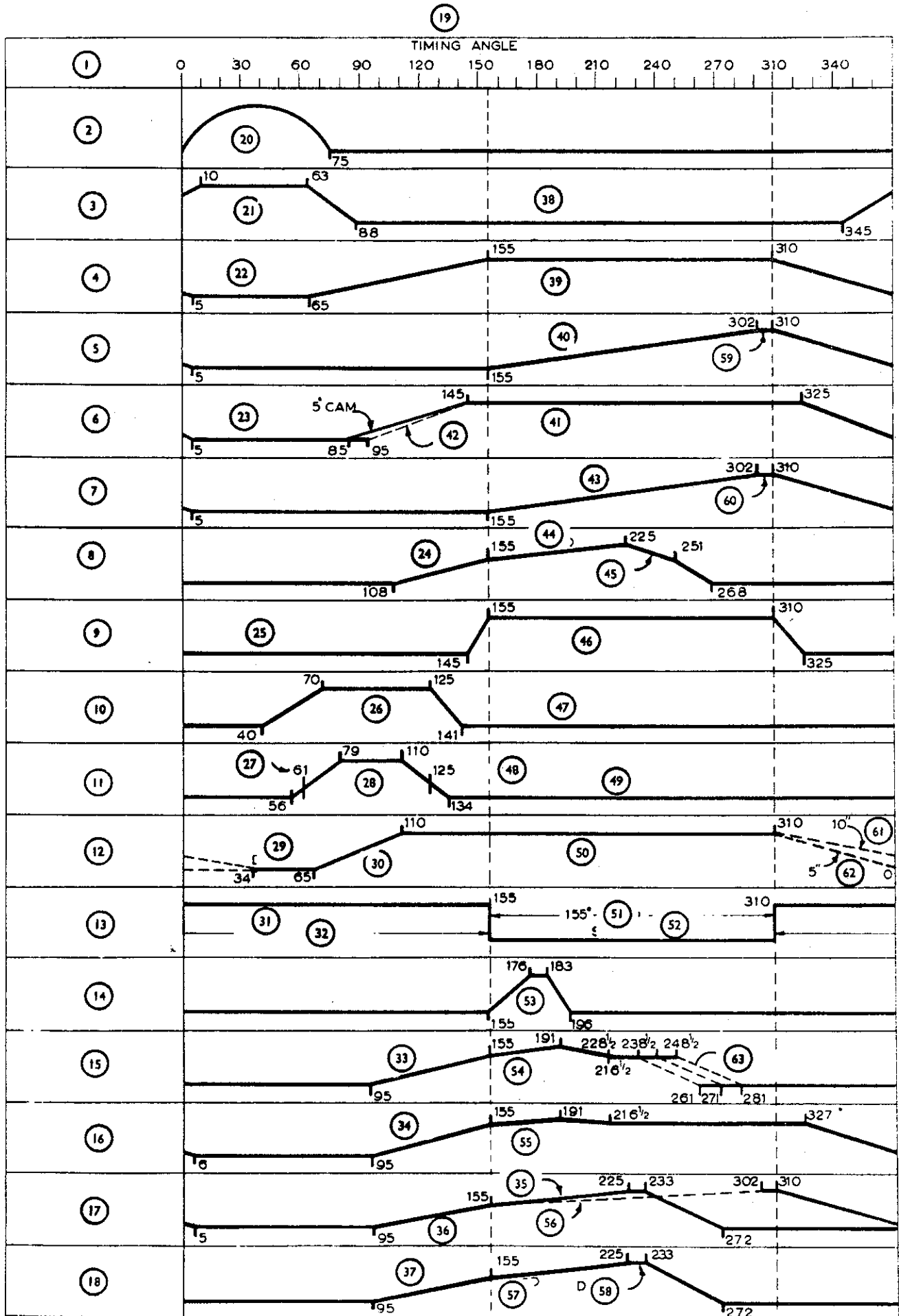

Scale Settings (1)

For stations 5 and 6 the following calculation applies:

To find scale setting required when using threading cams:

Scale setting in inches = Available cutting revs

2 x "On" ratio x t.p.i.

(Maximum scale setting is 5.1/2in)

For example, to cut a 20 t.p.i. thread using an "On" ratio of 5:

From speed and feed chart, available cutting revolutions = 100 (this is determined by the longest operation).

$$\text{Scale setting} = \frac{100}{2 \times 5 \times 20} = \frac{100}{200} = 1/2"$$

The feed stroke = one-third quadrant scale setting. The total stroke at the nuts "A" on the pusher rod = fast motion (5" or 3.1/2") plus one-third quadrant scale setting.

$$\text{Scale setting in mm} = \frac{\text{Available cutting revs} \times \text{Pitch}}{2 \times \text{"On" ratio}}$$

The total stroke of nuts "A" on the pusher rod = 4.75 x feed stroke required. See fig. 5.11.

Fig.5.11 Threading Attachment Stations 5 & 6

1. Front longitudinal slide Sec. 531.
2. Nuts 'E'.
3. Trip bush Sec. 388 Mk1.
4. Coolant inlet.
5. Threading spindle Sec. 386 Mk1.
6. Coolant inlet.
7. Nuts 'B'.
8. Locknuts Sec. 597D Mk1.
9. Threading brackets Sec. 597D Mk1.
10. Spring assembly Sec. 386 Mk1.
11. Tapping assembly.
12. Trip rod Sec. 597A.
13. Reset screw 'F' Sec. 597D Mk1.
14. Nuts 'A'.
15. Push rod Sec. 597D Mk1.
16. Clutch trip box Sec. 597B.
17. Front longitudinal motion Sec. 524.
18. Threading drive Sec. 597A.
19. Anchor plate Sec. 597A.
20. Threading drive Sec. 597A.
21. .875/.873 dia.
22. Trip rod Sec. 597A.
23. Nuts 'D'.
24. Locknuts Sec. 597D Mk1.
25. Body and slide Sec. 388 Mk1.
26. Revolving diehead assembly.
27. to clear 1/2 rod.
28. Material-mild steel.
29. Material-phosphor bronze PB.2C BS.1400.
30. Locknuts Sec. 597D Mk1.
31. Pull rod Sec. 597D Mk1.
32. Glut dimensions to suit diehead.
33. Threading spindle Sec. 386 Mk1.
34. Nuts 'C'.
35. Glut dimensions (see 32).
36. Note: Shorten screw by 1/8" to clear centre block.

Fig.5.11 Threading Attachment Stations 5 & 6

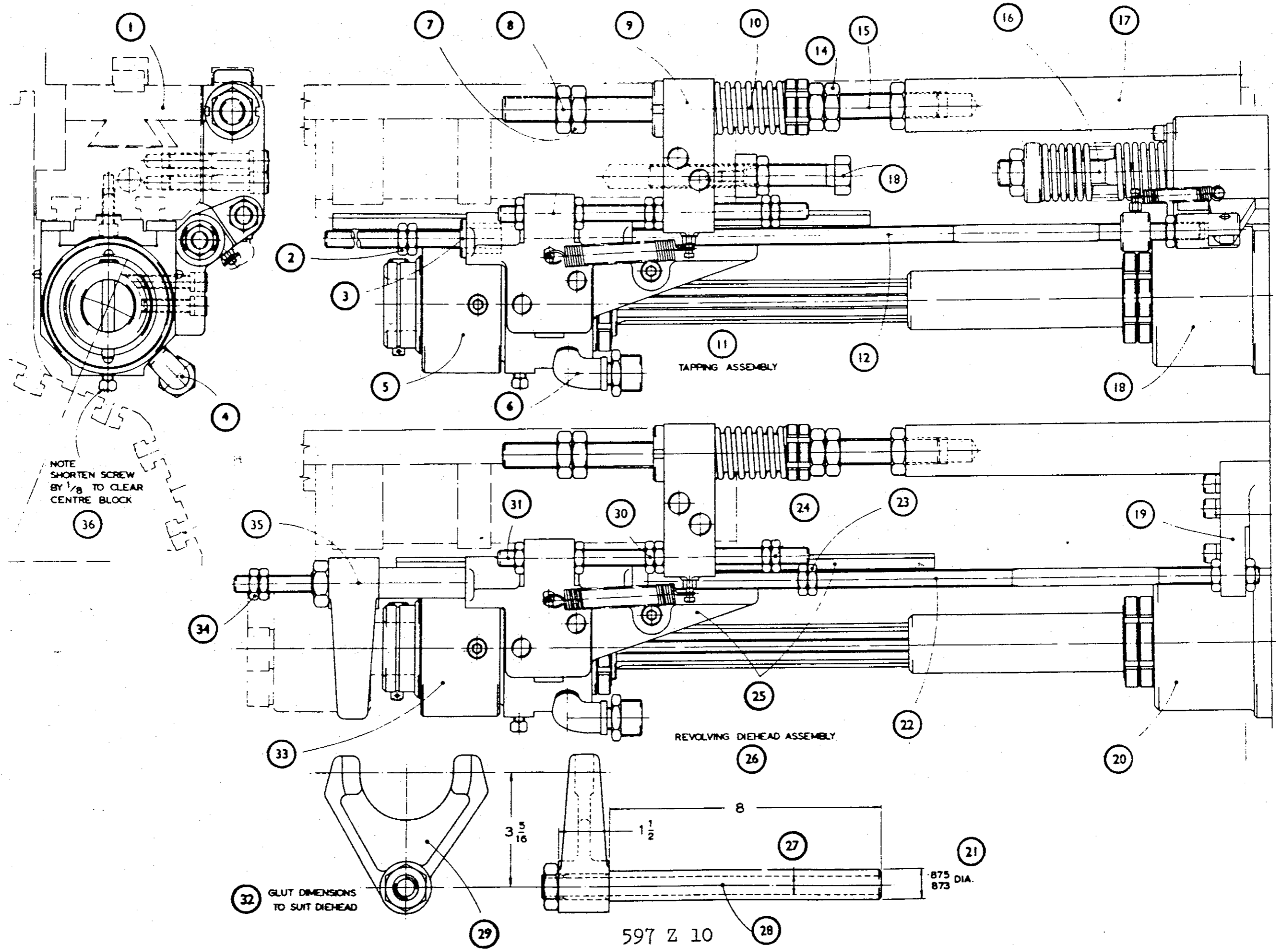

Scale Settings (2)

For stations 3,4,7 and 8.

Using threaded cams, the feed stroke required is first found from the formula given in the chart shown, fig.5.11, and the pivot position and pusher connection point also found on the chart.

The total stroke of nuts 'X' on the pusher rod (Fig. 5.3)
= approach stroke + feed stroke
= 3.75 X feed stroke + feed stroke
= 4.75 X feed stroke

Data to be given on the layout

The information obtained by methods explained in the previous pages should be incorporated in the tooling layout and not left for the setter to calculate. The following items for instance, should be considered essential:

1. Full details of sections to be used.
These can be found from the section chart, on fig.5.18.
2. Position of the jackshafts to be fitted.
3. The gears to be used on the drive units for "On" and "Off" ratios.
4. The cams to be used.
5. The scale settings or, in the case of stations 3, 4, 7 and 8.
6. The pivot position and the pusher connection point.

5.7 Fitting Drive Units, Jackshafts and Threading Units

Diehead Drive (Section 597A)

The main assembly, less the locknut is passed into the housing and locked into position with the locknut. The gear adaptor is then located in the drive sleeve bore with its slots engaging the dogs on the drive sleeve, and is secured by cap screws. The driven gear is then mounted on its adaptor and secured by cap screws. See fig. 5.8.

Threading Clutch Drive (Section 597B)

The end bearing housing is first fitted into the bore in the inner wall of the drive compartment and is connected to the oil supply. The gears 'B' and 'D' are fitted to the clutch unit which is then passed into the drive compartment, the rear bearing being fitted into its housing. Remove the locknut of the diehead drive and park it on the end of the clutch assembly. Pass the diehead unit through the attachment wall, engaging its dogs in the slots of the clutch shaft. Fit and tighten locknut on the diehead drive unit and tighten locking ring of the clutch assembly. The glut shaft is now fitted, the latch housing being fitted complete and the glut shaft threaded through the clutch glut. The shaft should be screwed into the glut until the latch just drops into its location when the clutch is in the 'ON' position. A spring loaded pressure disc relieves the spring pressure on the glut when the clutch is in the 'OFF' position.

When the clutch is used with a self opening diehead, the inner and outer spring assemblies are removed from the latch housing and replaced by a diehead anchor plate. The diehead trip rod is adjusted to retain the latch and the glut rod with the clutch in the 'ON' position. See fig. 5.9.

Clutch Adjustment

Both sides of the clutch should be adjusted to give a satisfactory non-slip drive in the "On" and "Off" positions. The clutch manufacturer recommends a maximum axial load of 75lb. on the clutch operating bobbin and this loading should not be exceeded. The glut spring should be removed and the clutch tested by levering with a bar between the main drive housing opening and the flats on the arms of the glut casting. A new clutch will not transmit full power until the friction surfaces have been bedded down. During the running-in stage one or two adjustments will be necessary, after which further adjustment will not be required for some considerable time.

The clutch is a wet plate type and requires a good oil supply on the plates to prevent undue wear and overheating.

Jackshafts

Gears are fitted to their respective centres and the shaft passed through the gear centres, the bearing and the sprocket. The whole is clamped up and the front housing secured. The jockey sprocket, fitted to the jockey arm, is fitted in the machine and the chain is then fitted, care being taken that the jockey is running on the slack side of the chain.

Threading Units

The threading slide is first fitted. When using Section 386 in stations 5 and 6, the threading slide is fitted on the longitudinal slide.

When using Section 386 in stations 3,4,7 or 8, the threading slide is fixed to the centre tool block and is positioned to minimise the overhang of the attachment on its slide during all movements of the attachment or centre tool block.

The trip rods and push rods are assembled to the attachment as shown in fig.5.11 (stations 5 and 6), fig.5.12 (stations 3,4,7 and 8) and the splined extension shaft with its nut fitted into the rear of the threading spindle. The attachment can then be mounted on to its slide and the shaft coupled to the drive unit and the rods and springs assembled. It should be noted that all brackets and rods may be fitted or removed from the attachment without disturbing the main body of the attachment if required.

The diehead, tap or dieholder is fitted in the bore in the front of the threading spindle and driven by a central pin through the shank. It is essential that the spring ring be replaced to retain this pin during running. When using solid taps or dies it is essential that some form of floating holder be used.

When tapping in stations 3,4,7 or 8, the reset bracket is attached to the central guide arm behind the centre tool block.

Coolant connections are provided in both attachments so that coolant may be supplied to the centre of the tap or die if desired.

The auxiliary longitudinal motion (Section 599A) must be fitted when threading is to be performed in stations 3,4,7 or 8. When threading in station 8 is to be combined with threading in stations 3,4, or 7, then section 599B is used in the 8th station.

Fig.5.12 Threading Attachment Stations 3,4,7 & 8

1. Station 7.
2. Coolant inlet.
3. Glut dimensions to suit diehead (see 597 E X 106).
4. Material-Phosphor bronze PB2C. BS.1400.
5. Trip bush Sec. 388 Mk1.
6. Threading bracket Sec. 597E Mk1.
7. Trip rod Sec. 597A.
8. Nuts 'V'
9. Threading spindle Sec. 386 Mk1.
10. Tapping assembly.
11. Reset rod Sec. 597E Mk1.
12. To clear 1/2 rod.
13. Material-mild steel.
14. Body and slide Sec. 388 Mk1.
15. Spring assembly Sec. 597E Mk1.
16. Nuts 'S'.
17. .875/.873 dia.
18. Clutch trip box Sec. 597B.
19. Upper pusher mechanism Sec. 599A.
20. Threading drive Sec. 597A.
21. Nuts 'Z'.
22. Anchor plate Sec. 597A.
23. Lower pusher mechanism Sec. 599B.
24. Body and slide Sec. 388 Mk1.
25. Nuts 'X'.
26. Spring assembly Sec. 597F Mk1.
27. Revolving diehead assembly.
28. Threading spindle Sec. 386 Mk1.
29. Glut dimensions to suit diehead.
30. Push rod Sec. 599B.
31. Threading bracket Sec. 597F Mk1.
32. Coolant inlet.
33. Station 8.
34. Nuts 'W'.
35. Trip rod Sec 597A.
36. Push rod Sec. 599A.

Fig.5.12 Threading Attachment Stations 3, 4, 7 & 8

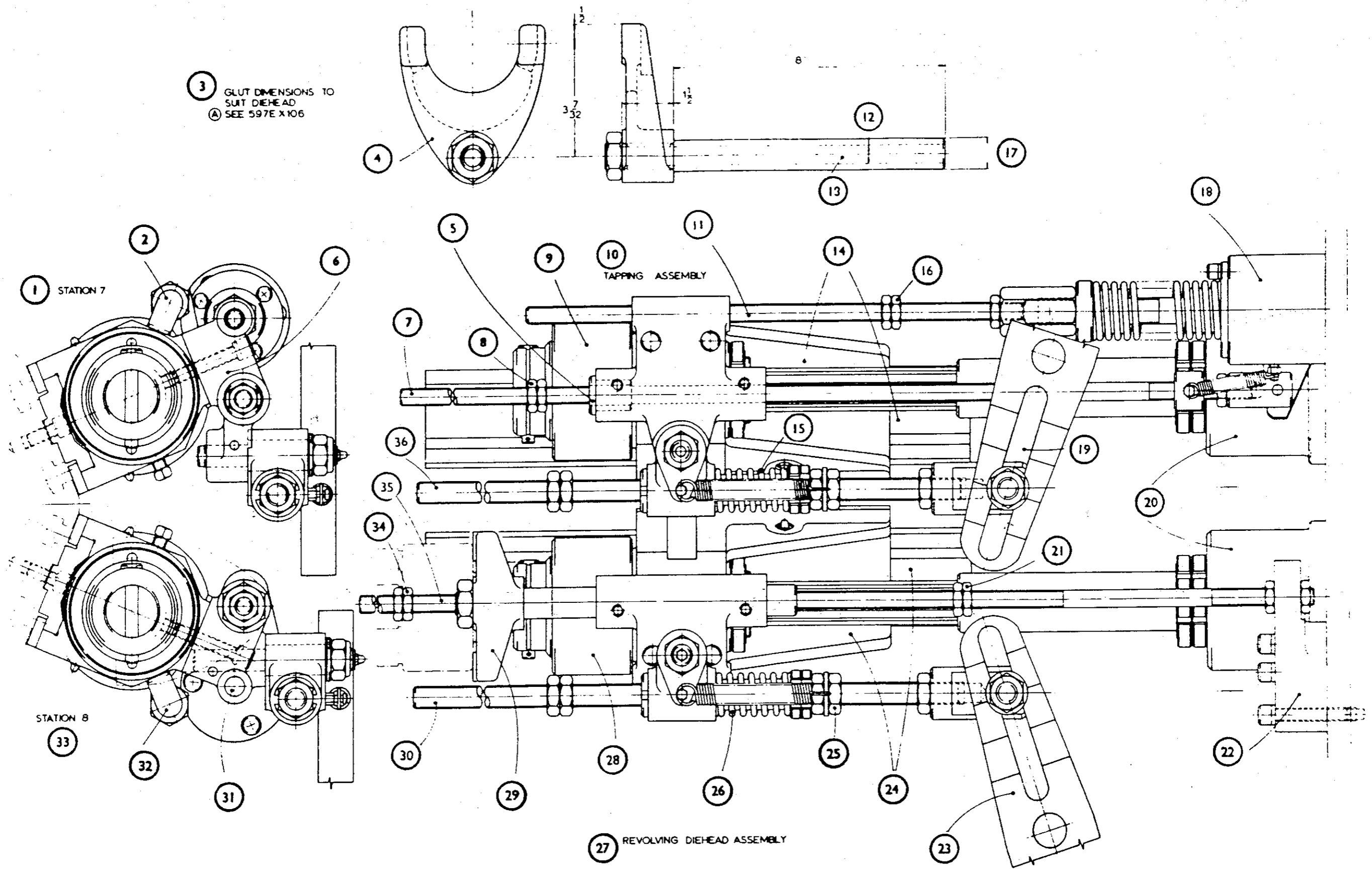

597 Z 11

5.8 Setting Threading Attachments (Section 586)

For use in stations 5 and 6.

Self-Opening Dieheads

Setting the attachment for self-opening dieheads when using the threading cams:

1. Set the quadrant scale setting.
2. Handwind to beginning of feed stroke.
3. Stations 5 and 6.
Set nuts "A" with the diehead just clear of the thread to be cut. If the thread length is less than one-third the scale setting, a minimum clearance of one-third the scale setting less the thread length must be set between the diehead and the work.
4. Set nuts "B" just clear of the push sleeve.
5. Set nuts "C" to open the diehead when the correct length of the thread has been cut.
6. Set nuts "D" to close the diehead when the attachment is fully back. If the thread lengths greater than 2in are to be cut, a minimum clearance must be set on nuts "B" equal to the thread length less 2in. See fig 5.11.

Solid Taps and Dies

Setting the attachment for taps or button dies. The threading cams must be used.

1. Set quadrant scale setting.
2. Handwind to beginning of feed stroke.
3. Stations 5 and 6.
Set nuts "A" with the tap or die just clear of the thread to be cut. If the thread length is less than one-third the scale setting a minimum clearance of one-third the scale setting less the thread length must be set between the tap or die and the work.
4. Set nuts "B" just clear of the push sleeve.
5. Set nuts "E" on trip rod so that clutch trips over when the tap has reached full depth. This can be done by setting the nuts clear of the bush by the amount of the thread length less 1/8in.
6. Set nuts "F" to first reset the clutch with the attachment fully back, without "crowding" the clutch bobbin and causing excessive wear and strain.
A longer pull rod will be required to cut a thread longer than 2in with a tap or button die. See fig. 5.11.

5.9 Threading Attachment

For use in stations 3, 4, 7 and 8.

Self-Opening or Solid Dies or Taps

1. Handwind the machine to the beginning of feed stroke.
2. Set nuts "X" so that the die or tap is just clear of the thread to be cut. If the feed stroke is greater than the thread length, a minimum clearance must be set between the tap or die and the work by the amount of the feed stroke less the thread length.
3. Set nuts "W" to open the diehead, or nuts "V" to trip the clutch, when the correct length of thread has been cut.
4. Set nuts "Y" to pull the attachment sufficiently clear of the work when parted-off. Ensure that the setting of these nuts does not interfere with the forward movement of the attachment when cutting.
5. (When using a self-opening diehead). Set nuts "Z" to reset the diehead when the attachment is in the fully back position.
6. (When using solid taps or dies). Set nuts "S" so that the bracket on the centre tool block just resets the clutch when the centre tool block is in its fully back position, without "crowding" the clutch bobbin and causing excessive wear and strain.

In all cases the slide must be set on the centre tool block to give the maximum support to the threading attachment in all positions of the attachment and the centre block. Should the stroke of the centre tool block be altered after setting for tapping, the clutch reset nuts "S" must be re-adjusted. See fig 5.12.

General Remarks

It is advisable to try out the threading attachment by the use of the inch button with the index clutch dis-engaged so that all settings and adjustments can be checked and adjusted as necessary.

Never handwind the machine through feed when threading is set.

When handwinding backwards, either relieve the nuts "A" or remove the tap or die. When using a self-opening diehead it may be tripped open in order to handwind backwards.

When setting, check movement of the attachment during cutting or backing-off, as movement will cease if the clutches slip. If this occurs, stop the machine and adjust the clutch, but do not adjust clutches too tight as this will cause excessive wear and strain and may prevent the clutch from fully engaging to run "Off".

Scale settings, clearances required and cams to be used should be specified on the layout and not left for the setter to calculate.

5.10 Chasing Attachments (Section 392 Mk.1)

This attachment can be fitted to the cross slides in 5th and 6th stations and comprises a chasing attachment unit, a drive unit and the drive gears.

Fig. 5.13 gives the capacity of the attachment and lists cams up to 4 t.p.i. and 6mm. pitch

Operation of the Attachment

The chasing slide and cutter is passed back and forward along the length of the component by the lead cam and is advanced into and retracted out of cut by the relief cam and tension spring. The two cams are carried on a camshaft in the attachment and driven from the drive unit. At the same time the attachment mounted on the cross slide is constantly fed forward by the standard cross slide cams.

During one revolution of the camshaft the chasing cutter advances to the work, makes one cutting pass along the component, retracts clear of the groove cut and returns back along the job to the start point.

The Drive Unit

592.N. (Fig. 5.14)

A chain drive from the centre shaft is taken to a special jackshaft unit fitted in the main drive housing. The front end of the jackshaft is connected to a gearbox mounted on the main drive housing attachment face. The final drive from the gearbox across to the chasing unit is by universally jointed shaft, which must be assembled so that the fork ends of the universal joints are in line.

The gearbox drive unit is fitted with two pick-off gears which are selected to give the ratio required to suit the job.

The ratio is the number of work spindle revolutions during one revolution of the attachment camshaft, ie. with a ratio of 6:1 the spindle revolves six times during one revolution of the camshaft.

The gears used depend on the lead cam and the thread to be cut.

The chart on fig.5.13 gives a list of threads per inch (t.p.i.) and show the gear ratios required for various cam leads. Metric threads are given in a separate table and listed under "Lead to be Cut" (or the pitch of the thread).

With any one lead cam, various threads can be cut by using different gear ratios. Ratios of 3:1, 4:1 and 5:1 are preferred to obtain the maximum number of passes of the chasing cutter during the cutting cycle, 3:1 giving the maximum number of passes.

The gear ratio must be less than the number of work spindle revolutions during 8 degs dwell (see feed and speed charts, pages 16 to 18. This ensures at least one complete pass during the dwell to a parallel thread.

Operators Notes

Fig.5.13 Chasing Attachment Sec.392 Mk1. Stations 5 & 6

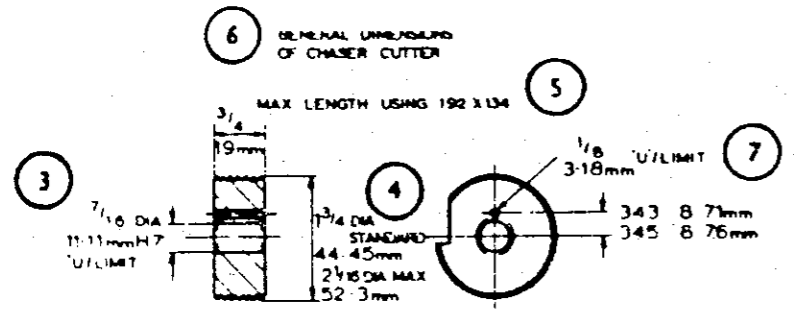

IF FOUND NECESSARY TO REDUCE CUTTING LOAD TEETH MAY BE GROUND OFF LEAVING 1 IN $\frac{RATIO}{2}$ TEETH (TAKE $\frac{RATIO}{2}$ TO NEAREST LESSER WHOLE NUMBER) E.G. USING RATIO OF 7 LEAVE ON 1 IN EVERY $(\frac{7}{2})$ TEETH 1 IN EVERY 3 TEETH

NOTE - THE USE OF 3:1 RATIO SHOULD BE AVOIDED WHEREVER POSSIBLE SINCE IT PREVENTS THE REMOVAL OF ALTERNATE TEETH

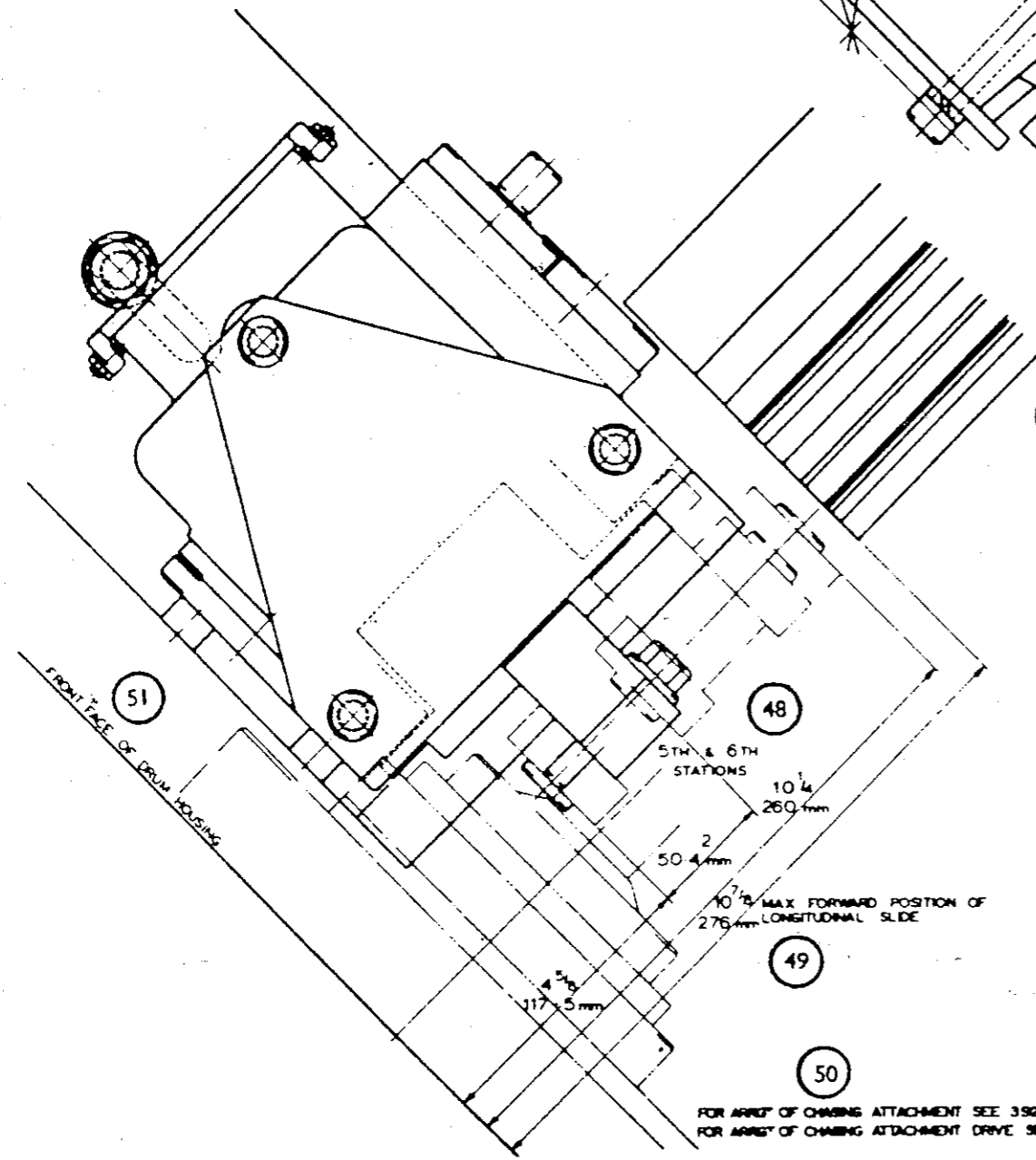
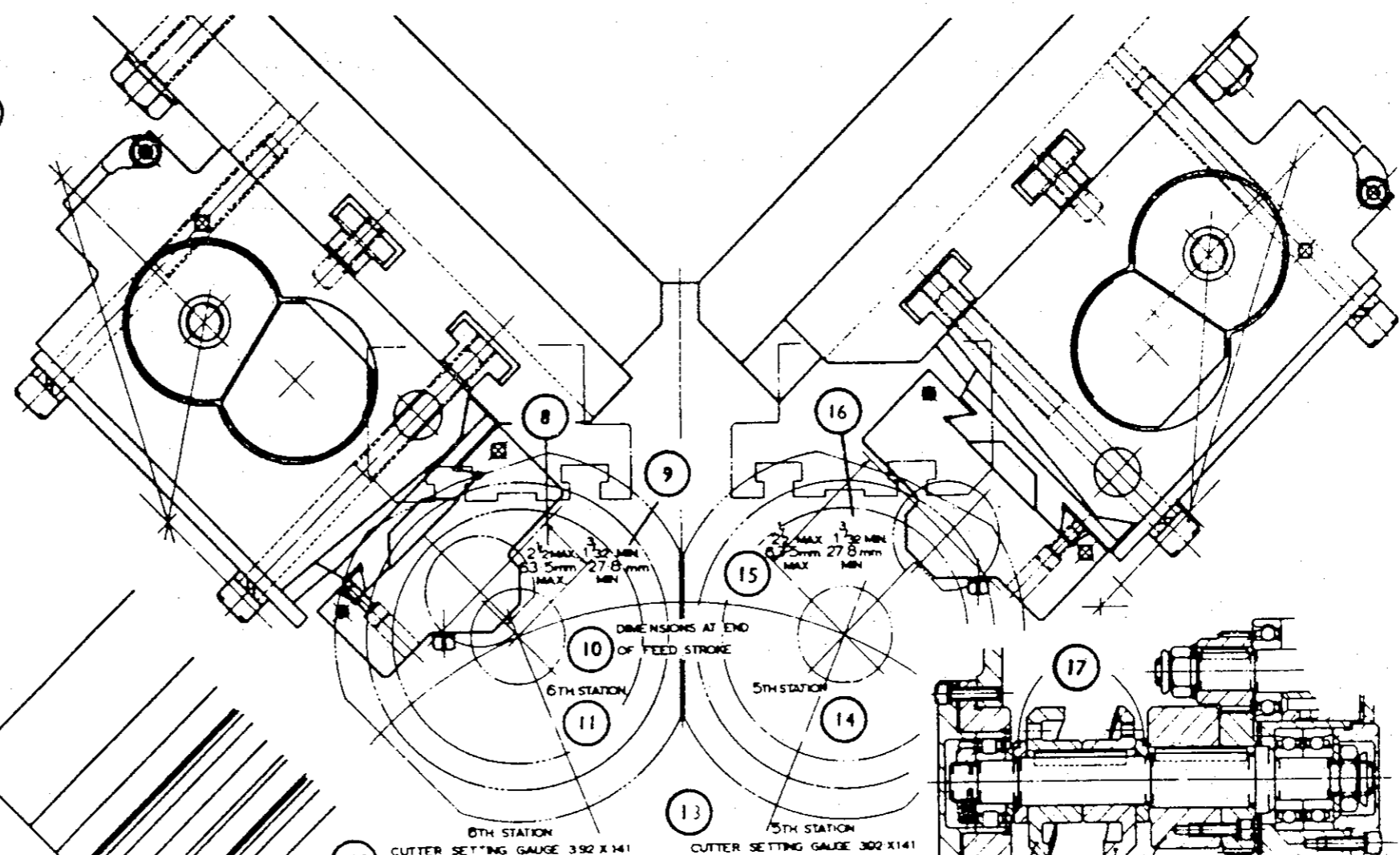

STATION	LEAD	RATIO	5	6	7	8	10
5	1.25	5					
7	1.25	5					
7.5	1.25	5					
8	1.25	5					
1	1.25	5					
1.25	1.25	5					
1.5	1.25	5					
1.75	1.25	5					

CAM LEAD	LEFT HAND THREAD	RIGHT HAND THREAD	SPACER
C27 + 1 PITCH	392 Y 151/11	392 Y 148/11	NOT
C28 + 1 PITCH	392 Y 151/23	392 Y 148/23	REC'D
C29 + 1 PITCH	192 BY 151/12	192 BY 148/12	
C30 + 1 PITCH	192 BY 151/37	192 BY 148/37	
C31 + 1 PITCH	192 BY 151/25	192 BY 148/25	
C32 + 1 PITCH	192 BY 151/41	192 BY 148/41	
C33 + 1 PITCH	192 BY 151/13	192 BY 148/13	
C34 + 1 PITCH	192 BY 151/413	192 BY 148/413	USE
C35 + 1 PITCH	192 BY 151/519	192 BY 148/519	2-OFF
C36 + 1 PITCH	192 BY 151/114	192 BY 148/114	392 X 153
C37 + 1 PITCH	192 BY 151/115	192 BY 148/115	WITH THESE
C38 + 1 PITCH	192 BY 151/116	192 BY 148/116	CAMS
C39 + 1 PITCH	192 BY 151/213	192 BY 148/213	
C40 + 1 PITCH	192 BY 151/117	192 BY 148/117	
C41 + 1 PITCH	192 BY 151/118	192 BY 148/118	
C42 + 1 PITCH	192 BY 151/119	192 BY 148/119	
C43 + 1 PITCH	192 BY 151/27	192 BY 148/27	
C44 + 1 PITCH	192 BY 151/25mm	192 BY 148/25mm	
C45 + 1 PITCH	192 BY 151/30mm	192 BY 148/30mm	USE
C46 + 1 PITCH	192 BY 151/4mm	192 BY 148/4mm	2-OFF
C47 + 1 PITCH	192 BY 151/5mm	192 BY 148/5mm	392 X 153
C48 + 1 PITCH	192 BY 151/7mm	192 BY 148/7mm	WITH THESE
C49 + 1 PITCH	192 BY 151/8mm	192 BY 148/8mm	CAMS
C50 + 1 PITCH	192 BY 151/10mm	192 BY 148/10mm	
C51 + 1 PITCH	192 BY 151/12mm	192 BY 148/12mm	
C52 + 1 PITCH	392 Y 151/14mm	392 BY 148/14mm	NOT
C53 + 1 PITCH	392 Y 151/22mm	392 BY 148/22mm	REC'D
C54 + 1 PITCH	392 Y 151/30mm	392 BY 148/30mm	

LEAD TO BE CUT	LEAD OF CAM	RATIO
5	1.25	4
7	1.25	5
7.5	1.25	6
8	1.25	7
1	1.25	8
1.25	1.25	9
1.5	1.25	10
1.75	1.25	11

500 Z 208

Fig.5.14 Chasing Attachment Drive 5th or 6th Station. Sec 592N Mk1

1. Jackshaft.
2. Universal joint fork end to be in line with slot.
3. Chasing attachment on cross slide.
4. Universal joint fork end to be in line with this hole.
5. Not applicable.
6. Special bolt, 6th stn. only. Sec. 592N Mk1.
7. Chasing attachment on cross slide, 5th & 6th stns. only Sec. 592N.
8. Not applicable.
9. Chaser bracket 5th & 6th stns. only. Sec 592N Mk1.
10. Jackshaft.
11. Attachment face main drive housing.
12. Reference No.
13. Number of teeth.
14. Driven.
15. Reference No.
16. Number of teeth.
17. Driver.
18. List of available ratios and pick-off gears.
19. Ratio.
20. Jackshaft rotates at spindle speed but in the opposite direction.

Fig.5.14 Chasing Attachment Drive 5th or 6th Station. Sec 592N Mk1

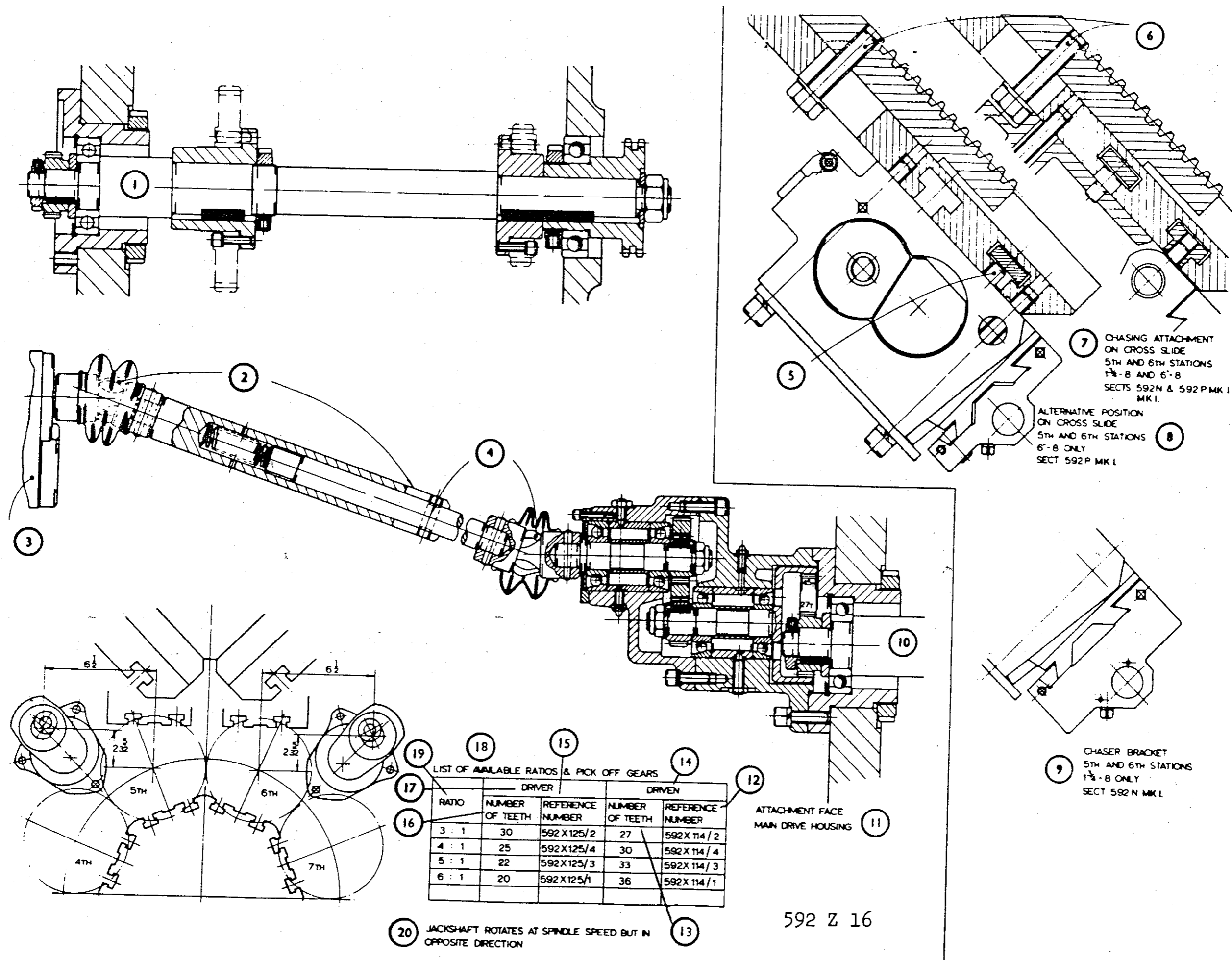

Changing Lead Cams

Remove attachment from cross slide.
Remove cover plate above chasing slide.
Release the tension on the relief spring and unhook it from the spring anchor.
Swing the slide forward until roller is free from lead cam.
Remove the large end cap on the face opposite to drive shaft.
Remove the camshaft nut, bearing and spacer.
The lead cam may then be removed. Extraction holes 1/4in BSF are provided in the inner cam.
The new lead cam is fitted in the reverse order, checking that there is clearance for the lead roller all the way round the cam track.

Chasing Cutter

This must be designed to suit the lead cut. The width of the chasing cutter may be determined by the job when threading behind a shoulder. The length behind the shoulder must be equal to the total travel due to the lead cam, plus the width of the chasing cutter, plus an allowance at each end for clearance. The minimum width of undercut required can be determined as follows:

$$\text{Minimum width of undercut} = .0725L + \frac{L}{R} + \text{clearance}$$

where L = lead of cam

R = ratio

clearance = .010in (.025 mm.)

If found necessary to reduce the cutting load, teeth may be ground off the chaser, leaving 1 in $\frac{R}{2}$ teeth.

(Take $\frac{R}{2}$ to nearest less whole number).

e.g. Using ratio of 7, leave one in every
($\frac{7}{2} = 3.1/2$) three teeth.
(2)

The chasing cutter is mounted on a removable bracket which clamps to the dovetail on the slide. A stop screw in the bracket can be set so that the bracket may be removed and replaced without altering the endwise setting. The height of the cutting edge is set from the edge of the bracket by the gauge provided.

Setting

The feed strokes set on the cross slide is set to the depth of thread plus .005in(.01 mm). This is so small that the stroke must be set and checked by using a dial indicator. With the cross slide at the start of the feed, mount a dial indicator so that it registers the stroke of the slide. Handwind to the end of feed and check the travel indicated adjust cross slide link until correct travel is obtained.

Taper in the thread can be eliminated by loosening the clamp bolts and adjusting the set screws in the strip behind the attachment. Ensure that all bolts are tight before running the attachment.

Left Hand Threads

Left hand threads are obtained by using left hand lead cams. The spring, plunger and cap in the attachment chasing slide must be reversed to give endwise pressure in the opposite direction. The gearbox drive assemblies for stations 5 and 6 are shown in fig. 5.14. Use medium to heavy oil in the two parts of the box.

Modifications to the diehead attachment when used in the same stations as chasing and modifications to the auxiliary longitudinal motion in 3rd and 6th stations are also shown.

5.11 Threading Attachment Return Check Switch

The return motion of a threading attachment can be restricted when a tap is forced into a partially drilled hole, or a die forced on to an unsuitable diameter, resulting in severe damage to the attachment if the machine indexes.

The return check switch mechanism is designed to stop the machine feed just before indexing if the attachment fails to return.

It consists of a bracket mounted micro switch with a spring cushioned bell crank lever, a spring operated rod, stop plate and electrical conduit and wiring. Failure to return keeps the switch closed, which in conjunction with the timing switch on the longitudinal camshaft disengages the electro-magnetic feed clutch at the end of the cycle and engages the brake.

The switch bracket is bolted to the main drive housing face and the stop plate screwed to the threading attachment. The operating rod carrying the springs and clamp is passed through the stop plate.

To set the mechanism, stop the machine with the slides withdrawn just before indexing and arrange the cam on the upper camshaft to operate the switch and de-energise the feed clutch and allow the brake to be engaged. Handwind back three turns of the handle and set the clamp on the operating rod to compress the springs and hold the micro switch in the closed position. Check that enough spring movement is available to cover any further return stroke.

It is advisable to check the action of the micro switch daily by holding the rod so that it does not operate the switch. In this condition the feed should be tripped when the attachment returns.

The return check switch bracket, rod etc., is supplied as standard with new threading attachments, and can be supplied to order for earlier attachments when the mechanism was an optional extra. The sets of uncommon parts are listed as 597H 3-7 on the chart shown in fig.5.18. The attachment is not considered necessary for stations where the component is parted off. The upper camshaft cam, switch and wiring, etc, is fitted as standard machine equipment.

The two switches, the check switch and upper camshaft switch, can be fitted by customers to existing attachments and machines. Electrical wiring is taken to an adjacent existing junction duct and the upper camshaft switch secured to the bracket carrying the existing feed knock-off switch.

The check switch can be prevented from working when threading attachment is not being used by tightening the screw and locknut provided against the bell crank with the switch in the operated position. See fig. 5.15.

Fig.5.15 Threading Attachment Return Check Switch

1. Set cam to operate micro-switch to stop machine just before start of indexing

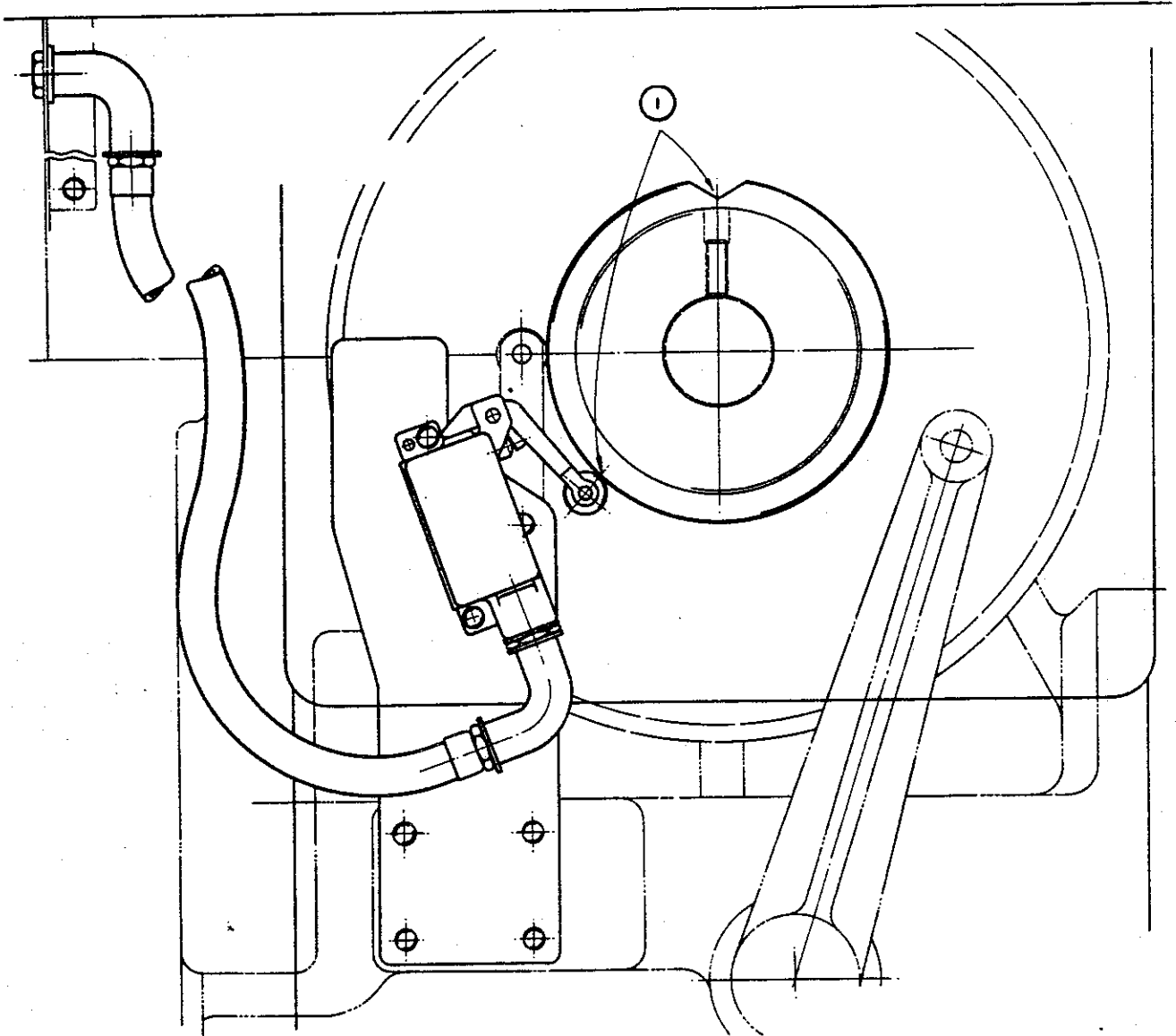

500 Y 196

5.12 Auxiliary Cross Slide Operation

For special purposes, where the timing of standard cross slide cams and operating mechanism is unsuitable, the two upper and the two intermediate cross slides can be operated from auxiliary cross slide mechanisms.

The auxiliary cam disc shown on fig. 5.16 is carried on the main camshaft in the drum housing and cams can be mounted on both faces. One cam operates the 3rd or 4th stations or 5th station only. The other cam operates either the 7th and 8th station or 6th station only.

A cam lever assembly actuated by the cams is connected through links to the operating lever and shaft of the slide requiring the motion, the standard linkage from the rocking levers being disconnected. The lever assembly has a split cap for the fulcrum boss and this fits on the upper lever pivot between bosses in the drum housing, on either side of the machine. A limited amount of adjustment of the ratio of cam stroke to slide travel is provided as given on fig.5.16.

Information for design of auxiliary cross slide cams is given on fig.5.16, and should be used in conjunction with the timing diagram, fig.5.10.

Fig.5.16 Auxiliary Motion

1. 1.3/4"-8 upper front stn.6 sec. 593B
rear stn.5 sec. 593A
2. Hole position.
3. Ratio of cross slide stroke to cam movement adjustable from:-
4. Radius 'R'. max. 6.1/4". min. 3.1/8". 3.1/8" cam movement.
5. 1.3/4"-8 Inter front stns. 7 & 8. sec 593C
Inter rear stns. 3 & 4. sec 593.
6. Ratio of intermediate cross slide to cam movement adjustable from:-
1.0 to 1.325.
7. Radius 'R'. Max. 6.1/4". Min. 3.1/8". 3.1/8" cam movement.
8. Rear Sec. 593A. Upper Sec. Intermediate.
9. Auxiliary cam disc:

Outside dia.	15.1/4"
Dia. of recess	14.3/4"
Depth of recesses	3/16"
Outside dia. of boss	4.1/2"
Cam thickness	11/16"
Dia. of roller	1.3/4"
10. Section A-A
11. Front section 593.B - Upper section 593.C. Intermediate.
12. 0 deg. timing hole.
13. Vee groove across diameter in line with key.
14. 36 - holes 7/16" B.S.F.

12 on 5.1/2" P.C. dia.
12 on 8" P.C. dia.
12 on 13.3/4" P.C. dia.
15. Rotation.

5.13 Synchronous Drive

Using 590.K
597.C

High Speed Drill Drive
Jackshaft

Fitting the above units and gears to the main drive housing enables a drive synchronous with the spindle speed to be taken from the splined shaft coupling of the high speed drilling drive unit. This drive is used for pick-up, flat milling, slotting, multi-drill head and drifting attachments, designed to suit customers' components.

Synchronous drive may be fitted in stations 3 to 8 inclusive, using high speed drilling drive, section 590K, or section 590L, without idler gear and pin assembly, and replacing driven gear 390 X 113 or 390 X 133 by 590 X 133 (38T cut on 39T). This is driven by jackshaft section 597C with drive gear 597 AX 105/38 in diehead position, i.e. 3.5/16in (84.14mm) from the attachment face.

See fig. 5.17 for limitations imposed when using a diehead drive in an adjacent station.

Fig.5.17 Synchronous Drive

1. Splined sleeve.
2. Driven gear 590 X 133.
3. When a diehead is used in a station adjacent to synchronous drive the following limitation apply:-

Synchr. drive in Stn.3 & diehead in Stn.4		max.threading spindle gear	= 33T
"	"	" 4	" 3/5 max.threading jackshaft gear = 34T
"	"	" 5	" 4 max.threading spindle gear = 33T
"	"	" 6	" 7 max.threading spindle gear = 33T
"	"	" 7	" 6/8 max.threading jackshaft gear = 34T
"	"	" 8	" 7 max.threading spindle gear = 33T

4. Jackshaft sprocket:- 1.3/4"-8 = 27T. 1.3/4"-8S = 21T.
5. Jackshaft Section 597C.
6. Drive gear 597 X 105/38.
7. High speed drilling drive Section 590K or 590L.

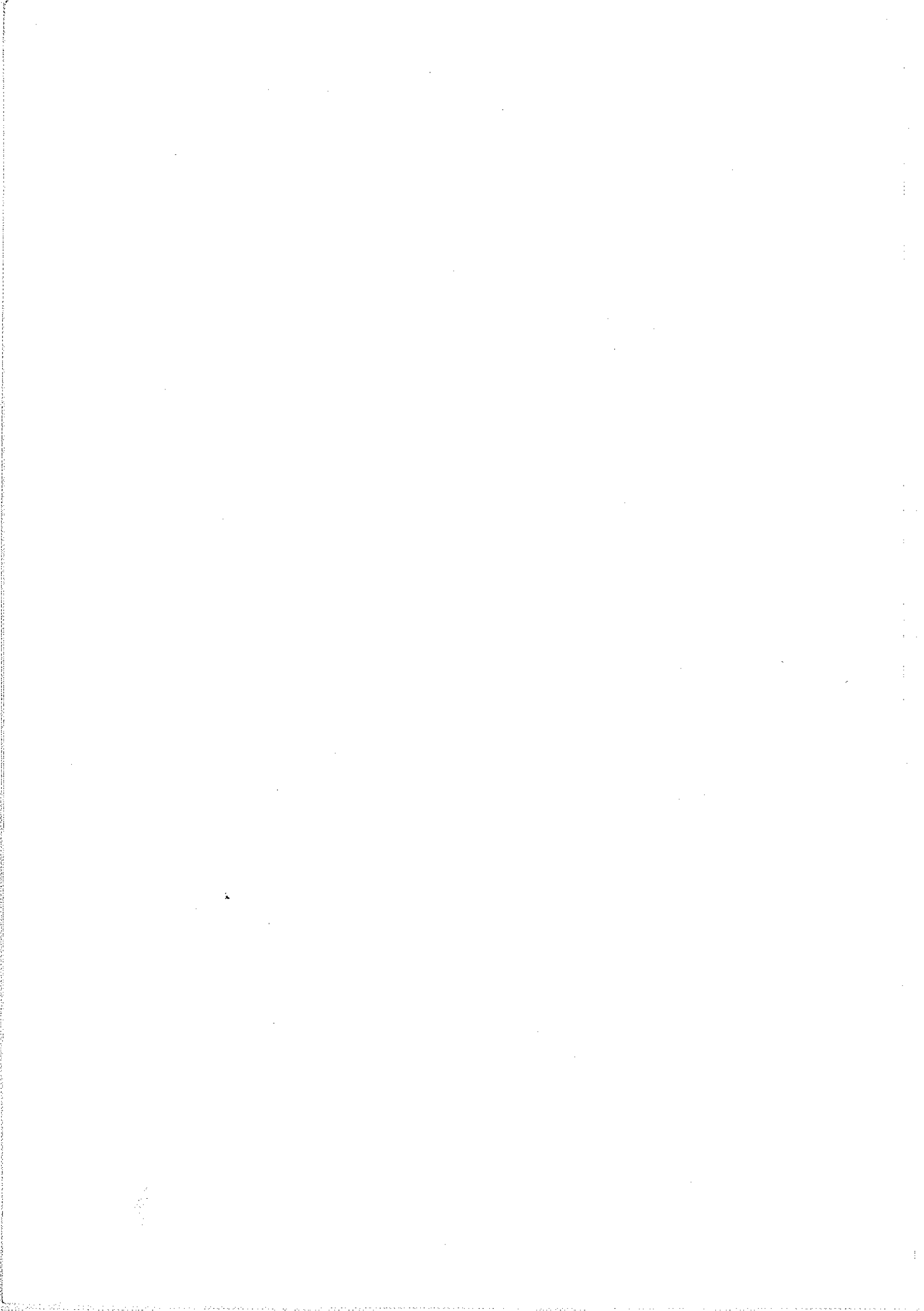
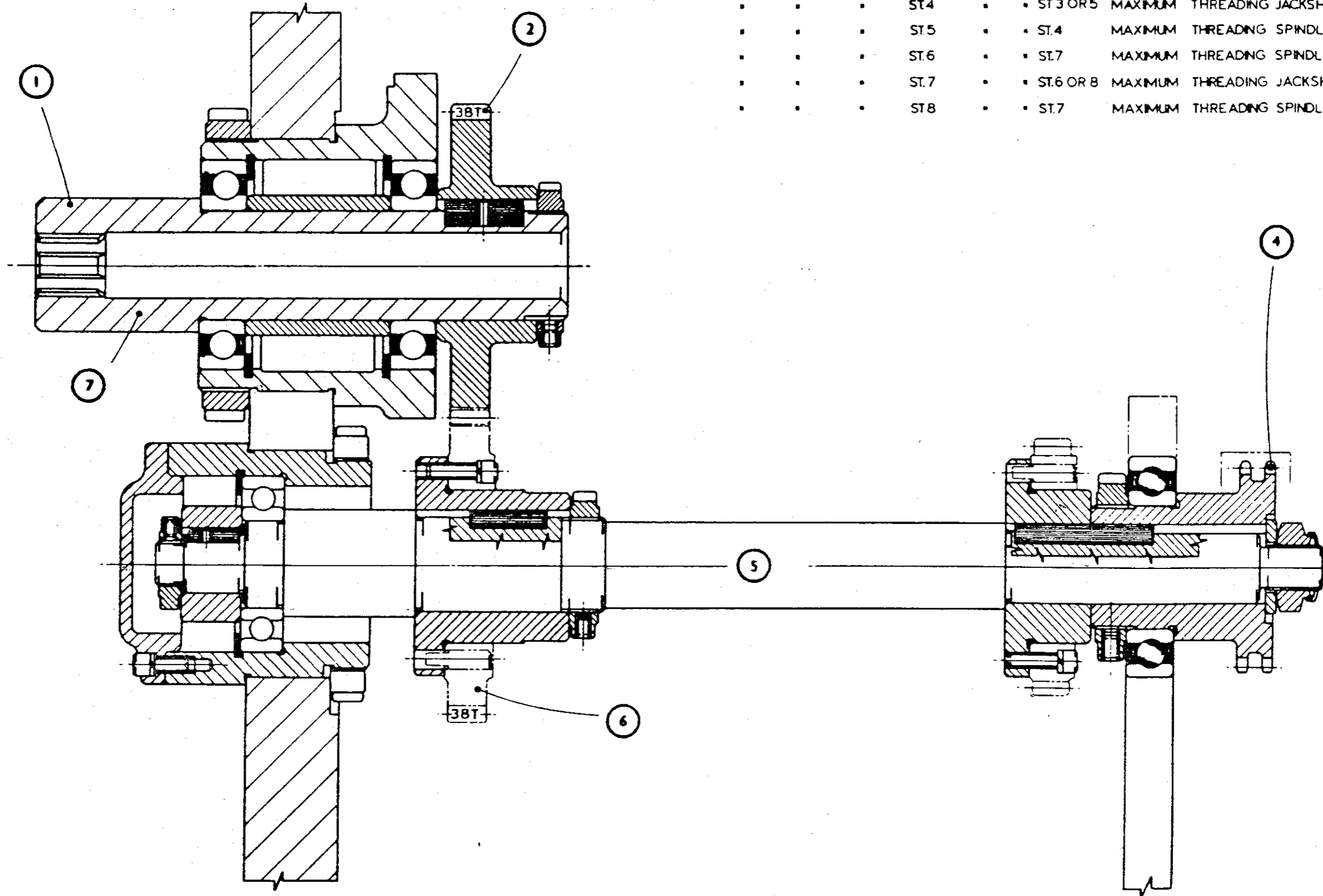

Fig.5.17 Synchronous Drive



3 WHEN A DIEHEAD IS USED IN A STATION ADJACENT TO SYNCHRONOUS DRIVE THE FOLLOWING LIMITATIONS APPLY :-

WITH SYNCHRON DRIVE IN ST.3 & DIEHEAD IN ST.4.		MAXIMUM THREADING SPINDLE GEAR	= 33T	
•	•	• ST.4	• ST.3 OR 5	MAXIMUM THREADING JACKSHAFT GEAR = 34T
•	•	• ST.5	• ST.4	MAXIMUM THREADING SPINDLE GEAR = 33T
•	•	• ST.6	• ST.7	MAXIMUM THREADING SPINDLE GEAR = 33T
•	•	• ST.7	• ST.6 OR 8	MAXIMUM THREADING JACKSHAFT GEAR = 34T
•	•	• ST.8	• ST.7	MAXIMUM THREADING SPINDLE GEAR = 33T

500 Y 215

5.14 Section Charts

1. Tooling arrangement
2. Threading with diehead in any one station
3. Threading with uni. clutch drive (solid taps/dies) in any one stn.
4. Threading with diehead and universal clutch drive in any two stns.
5. Threading with two dieheads in any two stations
6. Reaming with auxiliary longitudinal motion
7. High speed drill with independent longitudinal motion
8. Thread chasing
9. Auxiliary cross slide motion
10. 3-8 inclusive. High speed drill motion from centre block
11. 1 set 1 set
12. Includes lead cam - specify
13. Select 1 pair from 592 Z 15A
14. OR OR
15. Application drg. 593 Z 1 required for 1.3/4"-8
16. Application drg. 593 Z 1 required for 1.3/4"-8
17. 598D only required when Sec. 599B is fitted in station 8
18. See 597 A 2 1 to select gears
19. 1 jackshaft same ratio - 2 jackshafts different ratio
20. 597F only required when Sec. 599B is fitted in station 8
21. 599A to be fitted in stn. 8 unless reqd. in stn. 7 then fit 599B
22. Application drawing Nos.
23. Auxiliary longitudinal motion station 8
24. Auxiliary longitudinal motion stations 3, 4, 7 & 8
25. Threading attachment check return switch
26. Threading attachment extra parts to fit 186F station 7
27. Threading attachment extra parts to fit 186F station 6
28. Threading attachment extra parts to fit 186F station 5
29. Threading attachment extra parts to fit 186F station 4
30. Threading attachment extra parts to fit 186F station 3
31. Threading Attachment Mk.1 extra parts & cams station 8
32. Threading attachment Mk.1 extra parts & cams stations 3, 4, 7 & 8
33. Threading cams stations 7 & 8
34. Threading attachment Mk.1 extra parts stations 5 & 6
35. Jackshaft Mk.1
36. Threading clutch drive
37. Threading drive
38. Reaming attachment extra parts & cams station 8
39. Reaming attachment extra parts stations 3, 4, 7 & 8
40. Reaming cams stations 7 & 8
41. Reaming cams acc. timing stations 3 & 4
42. Reaming cams standard timing stations 3 & 4
43. Threading cams acc. timing stations 3 & 4
44. Threading cams std. timing stations 3 & 4
45. Threading cams stations 5 & 6
46. Auxiliary cross slide motion Mk.1 stations 7 & 8
47. Auxiliary cross slide motion Mk.1 station 6
48. Auxiliary cross slide motion Mk.1 station 5
49. Auxiliary cross slide motion stations 3 & 4
50. Chasing attachment drive Mk.1 6"-8 only
51. Chasing attachment drive Mk.1 1.3/4"-8 only
52. Chasing attachment drive gears
53. Chasing attachment Mk.1
54. Section 13. High speed drill spindle group K
55. High speed drill drive 1.3/4"-8 only toolholder bracket
56. High speed drill drive 6"-8 only
57. Body & slide Mk.1
58. Threading attachment Mk.1 common parts
59. Section No.
60. Section title
61. Stations

5.14 Section Charts

1. Section No.
2. Section
3. Title
4. Stations
5. Tooling arrangement
6. Threading with 2 uni. clutch drives in any two stations
7. Threading with 2 dieheads & 1 uni. clutch drive in any three stns.
8. Threading with 2 uni. clutch drives & 1 diehead in any three stns.
9. OR
10. See 597 AZ 1 to select gears
11. Extra jackshaft reqd. with different ratio in adjacent stations
12. 597F only reqd. in station 8 when sec. 599B is fitted
13. 599A to be fitted in stn. 8 unless reqd. in stn. 7 then 599B fitted
14. For synchronous drive see 590 X 13
15. For square longitudinal slides stns. 5 & 6 see 531 Z 51
16. Using diehead drive with differing ratios in adjacent stations.
Check that total number of teeth on gears on jackshaft & adjacent attachment drive spindles as shown below does not exceed 72 teeth
 1. Diehead drive in stns. 3 & 4 check J3,4 & att. bore stn.4
 2. Diehead drive in stns. 4 & 5 check J4,5 & att. bore stn.4
 3. Diehead drive in stns. 6 & 7 check J6,7 & att. bore stn.7
 4. Diehead drive in stns. 7 & 8 check J7,8 & att. bore stn.7
17. Using full threading drive in stn.8, use jackshaft J7,8 & check total No. of teeth on jackshaft 'ON' ratio gear & feed gear 'J' does not exceed 84 teeth.
Using full threading drive in stn.7, use jackshaft J6,7 RH & LH. full threading cannot be used in adjacent stns. except in 5 & 6.
Using diehead drives for LH threads in adjacent stn.
To high speed drill, the following restrictions apply:-
 1. With H.S. drill in stn.3 & diehead in stn.4 use jackshaft J4,5.
 2. With H.S. drill in stn.4 diehead in stn.3 or 5 cannot be used.
 3. With H.S. drill in stn.5 & diehead in stn.4 use jackshaft J3,4.
 4. With H.S. drill in stn.6 & diehead in stn.7 use jackshaft J7,8.
 5. With H.S. drill in stn.7, diehead in stns 6 or 8 cannot be used.
 6. With H.S. drill in stn.8 & diehead in stn.7 use jackshaft J6,7.
18. Aux. longitudinal motion station 8
19. Aux. longitudinal motion stations 3,4,7 & 8
20. Threading att. check return switch
21. Threading attachment extra parts to fit 186F station 7
22. Threading attachment extra parts to fit 186F station 6
23. Threading attachment extra parts to fit 186F station 5
24. Threading attachment extra parts to fit 186F station 4
25. Threading attachment extra parts to fit 186F station 3
26. Threading Attachment Mk.1 extra parts & cams station 8
27. Threading attachment Mk.1 extra parts & cams stations 3,4,7 & 8
28. Threading cams stations 7 & 8
29. Threading att. Mk.1 extra parts stations 5 & 6
30. Jackshaft Mk.1
31. Threading clutch drive
32. Threading drive
33. Threading cams. Acc. timing
34. Threading cams. Std. timing
35. Threading cams stations 5 & 6
36. Body & slide Mk.1
37. Threading att. Mk.1 common parts

